

Synthesiology

English edition

Development of a stable growth factor suitable for radioprotection

Development of a protein array for autoantibody profiling of blood

Technological development of internal heat-integrated distillation column (HIDiC)

Secure password authentication schemes and their applications

Development of environmentally-friendly surface modification technology

Synthesiology editorial board

Highlights of the Papers in *Synthesiology* Volume 7 Issue 3 (Japanese version Aug. 2014)

Synthesiology is a journal that describes the objectives and the social values of research activities that attempt to utilize the results in society, the specific scenarios and the research procedures, and the process of synthesis and integration of elemental technologies. The papers in this issue will be highlighted below to clarify their values.

Synthesiology Editorial Board

Development of a stable growth factor suitable for radioprotection

– Drug development-aimed R&D at a basic research institute –

The physiologically active protein “FGFC” that regulates cell functions was developed to reduce damage of the body from high-dose radiation exposure. Considering the fact that the pharmaceutical approval process of the radioprotective drugs is different from that of the general pharmaceutical products, efforts were spent on the selection and stabilization of the candidates for highly active molecules, the establishment of a mass production system, the application of molecular structures to medical use, and the clarification of the protective mechanism. The paper presents a long-term scenario as an effort of a basic research institute to send out a radioprotective drug with performance that surpasses the currently available agents to society.

Development of a protein array for autoantibody profiling of blood

– Comprehensive disease diagnosis using the body’s defense system –

In cases of diseases such as cancer, there is an excessive amount of antibodies against specific autologous proteins found in the blood serum, and it was shown that early diagnosis is possible through comprehensive detection of the autoantibodies. For this development, centering on the breakthrough construction of the “world’s largest human protein expression resource,” the paper presents the scenario for integrating elemental technologies such as the comprehensive protein expression technology, protein array technology, antibody detection technology, and screening technology.

Technological development of internal heat-integrated distillation column (HIDiC)

– Substantive research of application to a bench plant of bioethanol distillation –

To enable efficient distillation of substances such as biomass that tend to cause clogging, and to realize the essential goal of energy saving, internal heat-integrated distillation columns were developed, and the road to practical application was paved by conducting demonstration of a highly safe compressor-free bench plant. This paper describes a theory of project management that shows the process where the divergence between the equilibrium theory and non-equilibrium theory, which was a barrier to development, was overcome by fusing process system engineering and heat transfer engineering while collaborating with the bioprocess field.

Secure password authentication schemes and their applications

– How to achieve security with short passwords –

In the Internet community, the assets and rights may be exposed to danger if the passwords (keys) are leaked or stolen. Reverting to basic theories from the actual problems of password and key management, a key sharing method was devised and implemented to ensure safety in cases where leakage occurs on either the server or the client. Since security should be built on credibility, the method cannot be improved while subjecting it to social trial. It is important to conduct risk assessment where all problems are assumed and measures are taken beforehand.

Development of environmentally-friendly surface modification technology

– Practical realization of novel oleophobic coatings without relying on perfluorinated compounds and surface texturing –

To realize a solid surface where liquid droplets such as contaminated water are not likely to remain, a new technology, which does not require roughening or treatment by perfluorinated compounds that are substances of environmental concern, was developed, and the mass production technology was achieved in a short time through technological transfer. The paper describes an R&D strategy where, based on basic research that focused on the dynamic behavior of molecules on solid surfaces, the sol-gel method is introduced as the coating technology essential for practical application, and the elemental technologies of private companies are fused admirably.

Synthesiology – English edition Vol.7 No.3 (Dec. 2014)

Contents

Highlights of the Papers in Synthesiology

Research papers

- Development of a stable growth factor suitable for radioprotection 134 - 148
– *Drug development-aimed R&D at a basic research institute* –

--- T. IMAMURA

- Development of a protein array for autoantibody profiling of blood 149 - 157
– *Comprehensive disease diagnosis using the body's defense system* –

--- Y. KAWAKAMI and N. GOSHIMA

- Technological development of internal heat-integrated distillation column (HIDiC) 158 - 173
– *Substantive research of application to a bench plant of bioethanol distillation* –

--- K. KATAOKA and H. NODA

- Secure password authentication schemes and their applications 174 - 184
– *How to achieve security with short passwords* –

--- K. KOBARA and S.H. SHIN

- Development of environmentally-friendly surface modification technology 185 - 193
– *Practical realization of novel oleophobic coatings without relying on perfluorinated compounds and surface texturing* –

--- A. HOZUMI and C. URATA

- Messages from the editorial board** 194

- Editorial policy** 195 - 196

- Instructions for authors** 197 - 198

- Letter from the editor** 199

Development of a stable growth factor suitable for radioprotection

— Drug development-aimed R&D at a basic research institute —

Toru IMAMURA

[Translation from *Synthesiology*, Vol.7, No.3, p.140-153 (2014)]

We have developed a stable growth factor protein that is a promising candidate for a radioprotective drug suitable for treating biological damage caused by high-dose radiation. This stable growth factor, designated FGFC (fibroblast growth factor chimeric protein), demonstrates several advantages over existing drugs. Once approved, it can be stockpiled for radioprotection. We aim to develop this protein into a drug at the highest possible level achievable at a basic research institute.

Keywords : Radioprotection, radiation-induced damage, fibroblast growth factor, FGF, stable, crypt, survival

1 Introduction: Positioning of this paper in *Synthesiology*

This research places as its outcome the creation of a pharmaceutical product from a new protein in the advanced basic research phase, and intends to overcome the phase of R&D known as the “valley of death.” To achieve the pharmaceutical product outcome, it is necessary to engage in quality-controlled manufacturing, conduct clinical trials, and receive pharmaceutical approval. This entails the time span of over 10 years and billions of yens of R&D funds. Therefore, it is difficult to overcome the valley of death by a basic research institute alone, and product realization has not been achieved for this pharmaceutical product at the point of writing this paper. Some people think that the product realization of pharmaceuticals should not be a development goal of a basic research institute. However, the author believes that a basic research institute can contribute to product realization by optimizing the direction and stages of the R&D. The importance of protein pharmaceuticals is expanding rapidly, and six of the top 10 products were protein pharmaceuticals in terms of global pharmaceutical sales in 2012. This means that the future basic research for drug discovery cannot be discussed without taking the protein drug discovery process into consideration. Therefore, I think it is important to describe the research and the scenario for protein drug discovery conducted at a basic research institute in *Synthesiology*. This paper will discuss the development phases of the signaling molecule protein FGFC as a radioprotective drug candidate conducted by the Author *et al.*

2 Protection against biological damages by exposure to radiation

When an organism is exposed to radiation, various effects occur, though there may be differences in quality or degree. These are the cleavage of nucleic acids and the denaturalization of biological substances by active oxygen and free radicals that are produced by the excitation of water caused by the energy absorbed by the body, depending on the types of radiation such as alpha ray, beta ray, gamma ray, X-ray, or neutron ray. Many such effects are not favorable to biological activity. Since the organisms evolved to adapt to the radiation in the natural environment including cosmic rays, natural radiation from earth, and radiation derived from substances ingested as food, organisms inherently possess a molecular mechanism to overcome such effects. Therefore, most of the effects of radiations at the level present in the natural environment do not cause problems on the individual level. However, when there is exposure to extremely high level of radiation, damage always occurs in a short period (this is called the acute radiation syndrome, or deterministic effect), and this may override the natural healing ability of the organism, and may lead to death of an individual at the worst. Even at low-level exposure, damages may manifest at certain probability after some passage of time (this is called the late radiation injury, or stochastic effect) (Fig. 1).

Therefore, the primary measures against high-level radiation that occurs resulting from accidents or medical treatments are to block the organism from the radiation by physical means such as keeping a distance from the radiation source, or wearing masks to prevent taking in

Biomedical Research Institute, AIST Tsukuba Central 6, 1-1-1 Higashi, Tsukuba 305-8566, Japan
E-mail: imamura-toru@aist.go.jp

Original manuscript received January 9, 2013, Revisions received March 13, 2014, Accepted March 14, 2014

the radioactive substances or radioactive particles into the body. In preparation for situations where physical blockage is not possible, preventative methods using mainly chemical substances have been developed as secondary measures to reduce the effect of radiation on organism. Examples are methods such as using some compound to protect the readily affected biological substances such as nucleic acids by detoxifying the free radicals produced by radiation, or to chelate the radioactive substance that entered the body and to promote excretion from the body. However, these are passive measures.

Recently, third measures that can be called active measures have been developed. These are radioprotective methods using the biological mechanisms where molecules are used to act directly on the cells, which are the building blocks of organisms. In one case, it was found that a group of signaling molecules called the cytokine or cell growth factors, which possess the ability to maintain survival or promote reproduction of cells, show activities that prevent or reduce the radiation effect on cells. If a biological radioprotection method using such a signaling molecule group is combined with electromagnetic isolation, physical isolation, or protection by chemical substances, maximum protection against radiation damage can be expected in total. Therefore, we believe that there is a large potential for R&D in developing the signaling molecule with high protective effect, by mobilizing the latest knowledge of biomedicine as well as findings on signaling molecules (Fig. 1).

We hold a research paradigm where various applications are sought by focusing on the multiple functionalities of signaling molecules and through the clarification of new physiological functions and molecular mechanisms. In this paper, from the perspective of research for signaling molecules to achieve the application to protective drugs, we shall summarize the research so far and discuss future development. In the course of this research, we learned that the scenario for sending the product out to society differed between general drugs and radioprotective drugs. This means that the scenario in which

the efficacy is investigated through clinical trials conducted on patient population with target diseases as in general drug development cannot be used in the development of protective drugs for high-dose whole body radiation damage. The development of radioprotective drugs runs into more difficulty than the one for general drugs. In this paper, we describe the R&D scenario at a basic research institute for the drug discovery of radioprotective drugs.

3 Scenario to achieve the outcome of practical protective drugs and the synthesis method for its realization

We engage in the development of a radioprotective drug based on fibroblast growth factor chimeric protein (FGFC), a signaling molecule protein. The details of FGFC will be discussed later (chapter 7).

As a scenario to achieve a protective drug from FGFC, a candidate molecule for a radioprotective drug, we initially considered a linear development. The linear development is the course followed in the development of regular drugs, and it involves the following processes: 1) safety tests of pharmaceutical candidate substances, 2) efficacy trials of pharmaceutical candidate substances in treatment of patients with target diseases (in this research, biological damage by high-dose radiation exposure), 3) application for approval, 4) additional tests and reapplication as needed, and 5) pharmaceutical approval. However, we discussed the feasibility of this development according to this scenario with the physicians and researchers of radioprotection in Japan and overseas, people of the pharmaceutical authorities, and people of World Health Organization (WHO), and reached an understanding that such development was difficult. The main reason was because, there was normally no patient population with radiation exposure that would provide statistically significant analysis, and even if such population existed, it would not be ethically acceptable to set a placebo patient group as a control.

Therefore, we reviewed the scenario to develop the FGFC as a protective drug. Currently, most of the radioprotective drugs used in medical practice at times of emergency exposure accidents have also been shown to be effective as systemic radioprotective drugs that were developed as drugs for some other disease. Prior examples include the keratinocyte growth factor (KGF, will be explained later) and granulocyte macrophage colony-stimulating factor (GM-CSF) that were approved in the United States for the treatment of side effects of cancer therapy. In this research, such prior examples were positioned as scheduled composition, and we restructured the scenario for protective drug development in two stages (Fig. 2). In the first stage, the pharmaceutical approval will be obtained as a treatment drug for a patient group that actually exists, and in the following second stage, the use

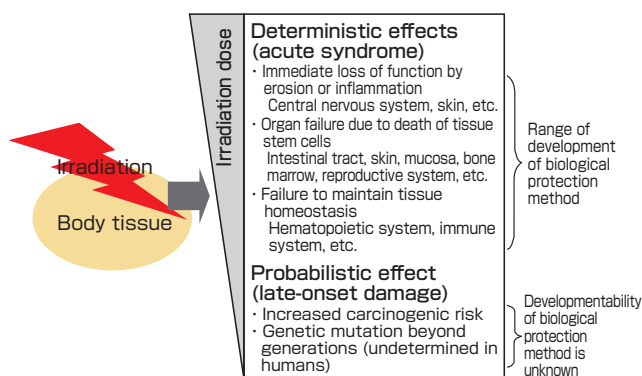

Fig. 1 Biological damage by radiation exposure and room for development of biological protection method

as a radioprotective drug will be achieved. Following the prior examples, the first stage for FGFC was positioned as the development of an agent mitigating side effects that would be approved as a drug to reduce the side effects of cancer therapy. In the following second stage, this drug once approved will be developed as a systemic radioprotective drug (Fig. 2).

3.1 Development of a drug to mitigate the side effect of cancer therapy using radiation

3.1.1 Course of development

The structure of this development policy follows the course of development of FGF7 (also called KGF), approved in the United States, that is used clinically as a side effect mitigator of cancer therapy and pharmaceutically.

The patient who receives chemoradiation therapy for cancer is exposed to a high dose of radiation. Of course, irradiation measures are taken to minimize the damage to normal tissues, but significant degrees of side effects do occur. Particularly, in cases where irradiation is done for head and neck cancer, severe erosion of the oral cavity mucosa occurs, and the patient complains of strong pain and becomes incapable of ingesting food or water. This is the major problem in this therapy. The FGF7 is administered preventatively or *post facto* to patients receiving such treatment, and has shown to greatly reduce the side effects and raise the patients' quality of life (QOL), and as a result increase the effect of cancer therapy. For drugs to mitigate side effects of the cancer therapy, because there exist

patient groups in which the pharmaceutical efficacy can be investigated, clinical trials can be conducted. Therefore, we plan to analyze the efficacy of FGFC by evaluating the mitigation activity against side effects in normal tissues of cancer patients receiving the radiotherapy.

3.1.2 Establishment of the production system toward approval

Whether it is a side effect mitigator for cancer therapy or a radioprotective drug for high-dose exposure of the whole body, the important common issues are the production and approval of the substance that possesses the quality required as a pharmaceutical. It is necessary to establish a system for mass-producing FGFC at high quality and stability using a method in compliance with the good manufacturing practice (GMP) standards. Then it is necessary to conduct the tests for safety and efficacy for the proteins produced by the established production system, and obtain approval as a drug.

3.1.3 Phase of pharmaceutical approval – Safety and efficacy tests and approval

The drugs used for humans must be safe. Therefore in the development of drugs, the presence of major problems to health is first checked through animal experiments. In the safety test conducted with animals for this purpose, it is required that the same drug administration route used for humans is employed. The protein formulation such as FGFC readily decomposes or is deactivated by digestive enzymes, and since the absorption in the digestive tract and efficiency of transition to blood are extremely low, oral administration is not suitable. Therefore, the protein formulation that must be activated systemically is generally administered intravenously, subcutaneously, or intramuscularly in humans.

After the safety in animals is confirmed, next, the safety in humans is investigated by first phase clinical trial conducted to healthy adult volunteers. If the safety is confirmed, the efficacy as a side effect mitigator of cancer therapy will be demonstrated in a clinical trial. If results suitable as a drug is obtained in the safety and efficacy tests, application is filed with the pharmaceutical authorities. When the approval is obtained, the side effect mitigating drug for radiation therapy is realized. However, large amounts of time and money are necessary to conduct trials in humans, and this surpasses the scale that can be undertaken by a basic research institute alone. Therefore, it is mandatory to form an alliance with external organizations such as pharmaceutical companies or NPOs. The optimization of the production method in compliance with the standards and safety and efficacy tests are done as a joint development with such external organizations.

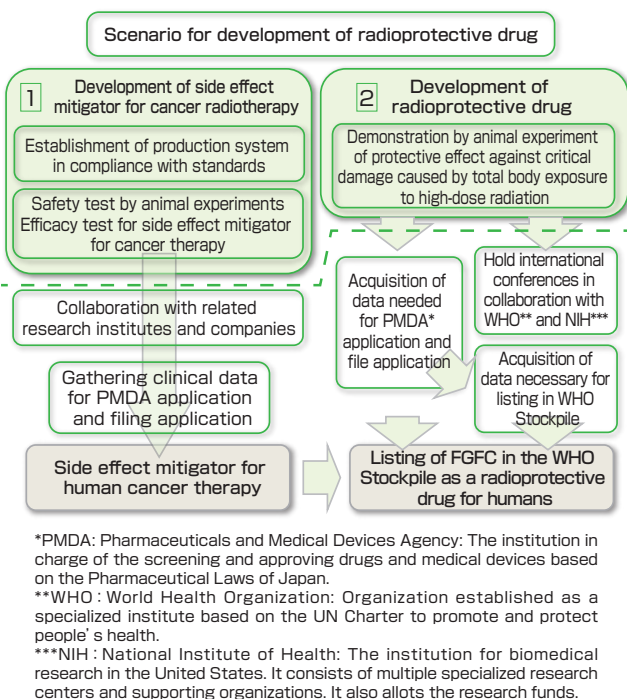

Fig. 2 Scenario to develop FGFC as a practical radioprotective drug

Consists of Phase 1 and Phase 2. The pale green area above the broken line is the part that can be conducted by a basic research institute.

3.2 Development of radioprotective drug for high-dose exposure to the whole body

3.2.1 Difficulty of conducting the efficacy test in humans

It is mandatory to demonstrate the efficacy as a radioprotective drug for high-dose exposure to the whole body. However, normally, a population of patients who have received whole body exposure of high-dose radiation do not normally exist, and it is difficult to investigate the efficacy in humans using the method generally used in drug development, such as comparing the improvement of symptoms between the two groups that were administered either the candidate drug or placebo. Therefore, it is important to demonstrate the protective efficacy against serious damage by whole body exposure to high-dose radiation mainly by animal experiments.

The investigation of efficacy in humans and the course to drug approval differ greatly from general drugs, as mentioned earlier.

3.2.2 Listing in the stockpile item recommended by WHO

The radioprotective drugs are not for treating general diseases, but are used in special situations. Moreover, the patient population in which the efficacy can be confirmed and the occurrences are extremely limited. It is difficult to grasp the market size. It is therefore thought to be difficult to objectively present the efficacy, which is the precondition to develop the product as a drug for a private company or research institution alone, or to present calculations that show the economic feasibility as a product. With this background, for the effective radioprotective drug for use in radiation accidents, WHO selects and designates effective items in a list named the "Stockpile List for Radiation Emergency" (hereinafter, will be called the WHO Stockpile) and reviews it once every few years. The last WHO Stockpile was created in 2007, and the stocking of the drugs according to this list is recommended for radiation organizations around the world. The WHO recommends that the facilities stock the items in the list in the "amount sufficient to treat 200 people for 10 to 12 days." The necessary stockpile around the world as calculated from this figure is fairly large. Also, since biopharmaceuticals of protein formulation have a relatively short effective period, a regular update of the stockpiled item is necessary. Therefore, many people think that the manufacture and sales of the radioprotective drug stockpile will be feasible for private companies and will contribute sufficiently to industry. The author thinks so, too.

Since 2007, the environment surrounding the radioprotective drugs is changing due to scientific advances and appearance of newly approved drugs. We learned that the WHO is thinking that it is time to review the stockpile list. Therefore, we set as a goal to have the FGFC placed in the WHO Stockpile as a radioprotective drug for humans. To achieve this goal, the important future issue is to appeal the efficacy

of FGFC to the radiation specialist communities at places such as international conferences.

4 Research objective and outcome: Scenario and strategy for the development of radioprotective drug – Use of a signaling molecule

Research objective: To develop a radioprotective drug using a signaling molecule in order to prevent as much as possible the biological damage caused by high-dose radiation exposure, to treat the damage that has been caused, and to restore a healthy body. Also, to provide the protocol for using this drug.

4.1 Scenario for radioprotective drug development particularly for internal exposure

Assuming a situation that requires a radioprotective drug after a radioactive substance has been taken into the body (internal exposure), the scenario for protective drug development can be set relatively easily. That is, the following measures are necessary:

- a. To expel the radioactive substance that entered the body, and
- b. To prevent the radioactive substance that entered the body to become incorporated into the target organs and cause damage.

Currently, among the protective drugs designated as the stockpile items of radioprotective drugs, the measures for "a" include Prussian blue and diethylene triamine pentaacetic acid (DTPA), and the measure for "b" include potassium iodide.

Since the Prussian blue and DTPA of "a" have the characteristic of bonding with the radioactive cesium or plutonium, when the person who ingested such radioactive substances is orally administered such protective drug, a cohesion is produced in the digestive tract and the substance is excreted from the body. The damage to the cell is reduced by reducing the time such radioactive substances remain in the body. On the other hand, potassium iodide of "b" utilizes the fact that the chemical form is the same as the radioactive iodine in the body of the person who ingested it.

Since radioactive iodine is highly volatile, it disperses in the atmosphere as gas and enters the blood through respiration. It is then likely to be incorporated into the thyroid gland, which is the organ that produces hormone using iodine as the important component. It is thought that the occurrence of thyroid cancer in children may increase due to this effect. Therefore, if the exposed individual takes non-radioactive potassium iodide, the incorporation of radioactive iodine to the thyroid gland can be reduced greatly.

As it can be seen, even though there is a difference in individual and tissue level between “a” and “b,” both are protective drugs where the principle is to reduce the damage to the body by reducing the exposure through distancing the radioactive substance from the body.

4.2 Scenario for signaling molecule development as a biological protection drug independent of the exposure form

Regardless of whether the exposure is external or internal, it is necessary to conduct effective protective measures in case high-dose exposure cannot be avoided. The damage by exposure to radioactive substances that are incorporated into the body is the same as the damage by external radiation, excluding the point that the distance between the radiation source and the target tissue is short. The following active mechanisms of radioprotective drugs are thought to counter the damage:

- a. To prevent the denaturalization of cell components by radiation, such as DNA damage or cell death,
- b. To restore the cell components that was denatured, such as DNA that was damaged by radiation, and to prevent cell death, and
- c. To promote growth and differentiation of the surviving healthy cells to supplement the cells that died due to radiation.

Of these, free radical scavenger “edaravone” can be given as an example of protective drugs that is a chemical substance with mechanism of “a.” Similarly, it is thought that substance that enhance production and activity of superoxide dismutase (SOD) that is the antioxidant enzyme in the cell acts to counteract the free radicals. It is also thought that the denaturalization of biological molecules by radiation occurs indirectly through the production of free radicals by radiation, and the scavengers that counteract such activity are widely effective.

On the other hand, mechanisms “b” and “c” are mainly the function of biological radioprotective drugs. The biological radioprotective drugs that are currently used in practice include the signaling molecules (bioactive proteins that are created by the cell of the body and acts on the cells) that act on the blood cells and immune systems. The granulocyte colony stimulating factor (G-CSF) is an example. The G-CSF is a signaling molecule that acts only on the growth differentiation of the blood cells, or the free cells that function in the blood or lymph such as erythrocyte, leucocyte, macrophage, and others. This acts to improve the aplastic blood cells. Also, other development candidates include the signaling molecules that target the blood and immunity cells such as thrombopoietin (TPO) receptor agonist, erythropoietin (EPO), interleukin (IL)-3, IL-7, and IL-11.

However, somatic cells such as the intestinal mucosal cell, vascular endothelial cell, hepatic cell, and fibroblast, which are the main cells that constitute the organs that are affected readily by high-dose radiation and may acutely threaten the life of an individual, have origins and functions that differ greatly from the blood cells, and the aforementioned signaling molecules do not function. The inability to use the molecules to protect such cells against radiation damage is a major problem, and the development of signaling molecules with such activities must be done quickly. Of course, the scenario may involve the maximization of radioprotective effects by combining the two.

5 Deepening of the scenario: Selection of the signaling molecule FGF – Selection of FGF1 and the issue of overcoming instability

In the aforementioned situation, it was reported that “Palifermin,” a drug that was approved by the US pharmaceutical authorities for the treatment of oral mucosal inflammation resulting as a side effect of chemoradiation therapy for cancer, was effective as a radioprotective drug.

In fact, this drug was part of the family of fibroblast growth factors (FGF), for which we have been conducting basic research over the years. It is a molecule called the FGF7 (KGF). The FGF family consists of 22 types of genes/proteins, from FGF1 to FGF23, and the molecule have similarities and differences in structure and bioactivity. We thought that the FGF family would have high potential as a radioprotective drug. Therefore, we proposed a research plan with the objective of developing a highly effective radioprotective drug to prevent and treat biological radiation damage using the FGF activity, and this plan was selected by the Budget for Nuclear Research of the Ministry of Education, Culture, Sports, Science and Technology (MEXT).

First, the factors expected to have radioprotective activity among the 22 molecules existing naturally as the FGF family were investigated, and their activities were compared in animal experiments using mice. The cell damage of intestinal crypt, which may be critically damage enough to threaten life, was selected as the analysis item of radiation damage, and the radioprotective activity was compared using this item as an index. It was found that compared to FGF7 and FGF10 that had similar activity to FGF7, FGF1 showed stronger radioprotective effects (Fig. 3).^[1]

However, FGF1 had a disadvantage in using it as a pharmaceutical drug, because the natural form of FGF1 was unstable physicochemically and bioactively. Therefore, the development of stabilized FGF (FGF1) arose as a technological challenge that had to be overcome.

6 Scenario for the development of stabilized FGF: Part 1 – Development of PG-FGF1 and the issues due to its novelty

We aimed for the pharmaceutical application of FGF1 from various bioactive aspects, but reached the understanding that the greatest issue in its application was its low stability. Therefore, we attempted the stabilization of FGF1 through various approaches. The molecule group PG-FGF1 that was planned and created based on the scientific findings was our prime result.

To explain the molecular structure of PG-FGF1, we must first explain the mechanism of the FGF action. The FGF binds to the extracellular domain of the FGF receptor that is exposed on the surface of the target cell. This causes the structural change of the receptor, and activates an enzyme called tyrosine kinase on the extracellular domain of the FGF receptor. In that reaction, it is necessary to acquire the cooperation of the sugar chains on the cell surface to obtain the optimal activation and strong binding with the FGF molecule receptor (Fig. 4).

This sugar chain belongs to the category called the sulfated glycosaminoglycans, and belongs mainly to the molecular group called heparan sulfate. Here, it is called a molecular group because it shares similar sugar chain skeletons with diverse microscopic structures such as sulfates. The biological protein covalently bound to sugar chains, such as heparan sulfates, is called proteoglycan (PG). One of the biological importance of this sugar chain is that the structure and activity of FGF can be stabilized through the binding of heparan sulfate sugar chain and FGF. Therefore, to stabilize the structure and activity of the FGF1 protein, we considered

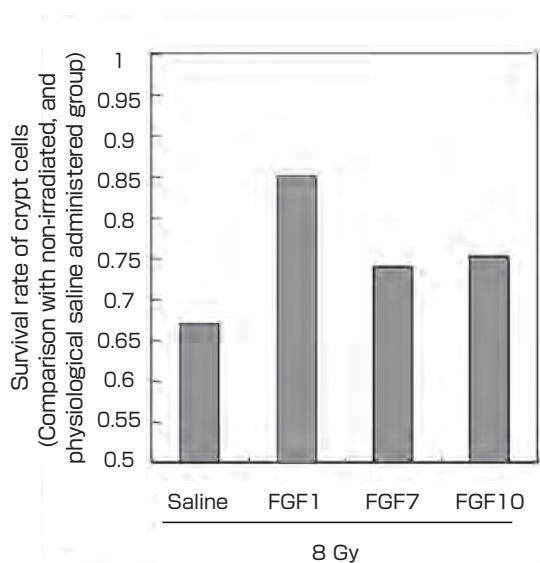

Fig. 3 Comparison of survival rate of intestinal crypt cells 2.5 days after exposure when various FGFs are administered before radiation exposure

binding the protein and heparin sulfate through covalent binding without depending on the force of the molecules on the cell surface. Therefore, we succeeded for the first time in the world to create a single molecule of proteoglycan and FGF1, and named this PG-FGF1. The PG-FGF1 has been shown to have ideal property as a drug, such as an increased activity in the inflammatory environment as well as a stable property (Fig. 5).^{[2]-[10]} It is thought that the property of this molecule is ideal also as a radioprotective drug.

However, there were issues to be solved in using the PG-FGF1 as a radioprotective drug. Roughly divided, the issues are the problem of pharmaceutical approval including quality control, and the technological issue for its production. These issues are universal technological issues accompanying the production of complex carbohydrates (or the majority of the glycan pharmaceuticals), and a long time is needed for solving the basic issues. Therefore, as Scenario 2 in this study, we decided to select the FGFC with less unsolved issues in production processes. The details of this process will be described in some other occasion and will not be addressed in this paper.

We changed the development scenario drastically, and decided to develop a radioprotective drug based on the highly stable FGF (FGFC will be described below) for which the development as a protective drug is expected to be accomplished in a short time because it is a simple protein that can be produced by *E. coli*. The following chapters will describe FGFC. We also think that both PG-FGF1 and FGFC will be better than the current FGF drug when used as radioprotective drugs. If both drugs are created, we expect the PG-FGF1 to have higher efficacy due to the superior principle. Following this way of thinking, if a radioprotective drug using the current FGF drug is considered to be the first generation, FGFC can be set as the second generation, and PG-FGF1 the third generation (Fig. 6).

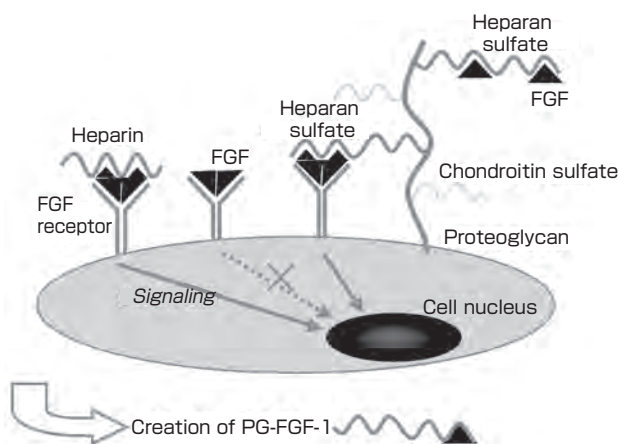

Fig. 4 For the activation of growth factor FGF signaling, the coexistence of glycosaminoglycan sugar chains such as heparan sulfate is mandatory. PG-FGF1 is a molecule in which FGF1 and heparan sulfate are united.

7 Scenario for the development of stabilized FGF: Part 2 – Development of FGFC and its property

7.1 Idea for FGFC

As mentioned in chapter 5, while the PG-FGF1 was fabricated in a logical approach with the objective of creating a superior-function FGF based on scientific findings, FGFC was a high-function molecule obtained by luck. FGFC is an artificial protein produced using *E. coli* and chimerization

of a number of FGFs in a cassette format. Since there are multiple combinations for chimerization, here, we use the term FGFC as the general name for several molecular groups.

The basic idea for FGFC was born back in 1988. At that time, the evaluation for the use of FGF as a pharmaceutical was undetermined, and its use as a radioprotective drug was not considered at all. I started the research of molecular biology as a visiting researcher at an American laboratory where Dr.

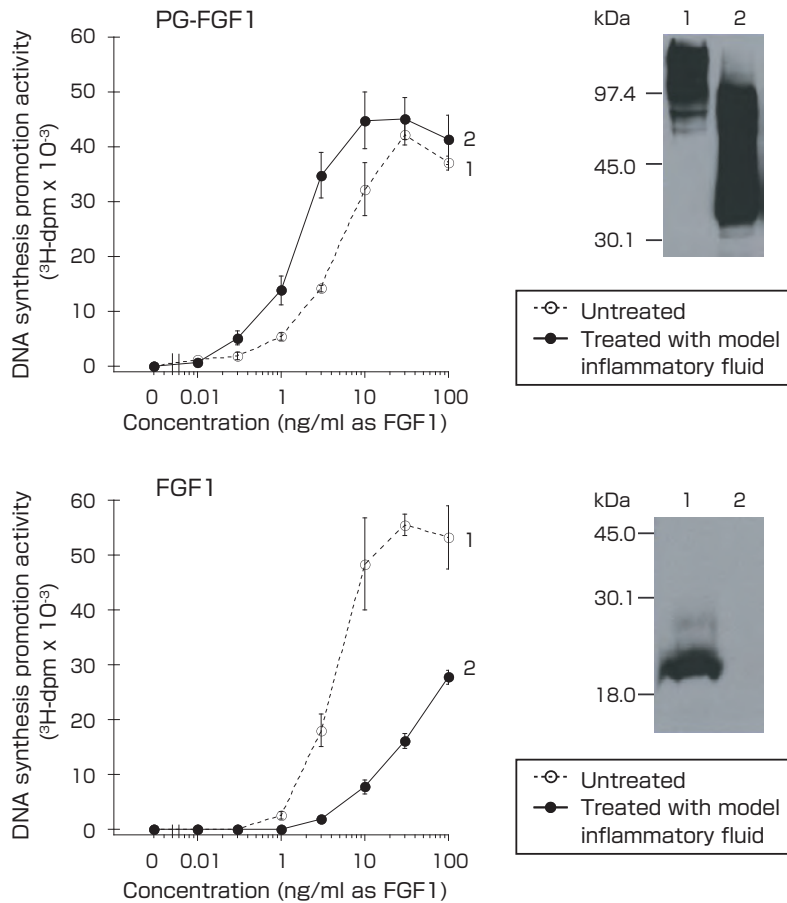

Fig. 5 The activity of PG-FGF-1 is strengthened in the inflammatory environment (top left). This is thought to occur as the sugar chain decomposes partially and functions as an activator of the FGF1 (top right). The natural form FGF1 is decomposed by the enzyme in the inflammatory liquid (lower right), and loses its activity (lower left).

[Data taken partially from Yoneda *et al.*, *Nature Biotechnology* (2000)]

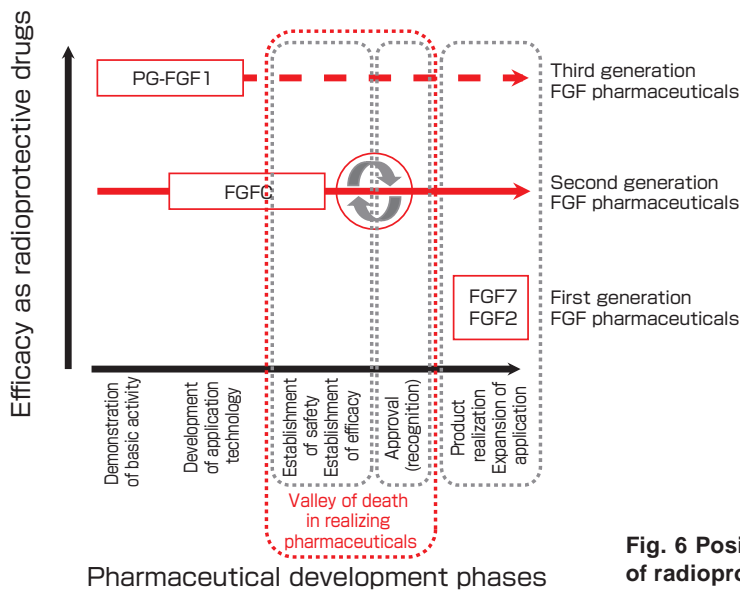

Fig. 6 Positioning of PG-FGF1 and FGFC in the development of radioprotective drugs that employ the FGF activity

Maciag discovered FGF1. At the time, the primary structures of FGF1 and FGF2 had just been clarified. In the research I had done in Japan, I had found that there were similarities and differences in the properties of FGF1 and FGF2, and in the US, I worked on the research to clarify the molecular structures of FGF1 and FGF2 that would be the foundation of their properties. I constructed several types of artificial genes (cDNA) of FGFC by synthetic oligonucleotides and a cassette shuffling method, translated them into protein, and conducted bioactivity analysis of a number of the resulting proteins. During the research, I encountered many problems such as the limitation of experimental methods available at the time and low reliability of the nucleic acid synthesizer, but I was able to complete the construction of the genes for all FGFC as initially planned.

7.2 Establishment of the mass production system for FGFC

The reason FGFC is superior to PG-FGF1 at this point in terms of practical use is that it is a simple protein that can be easily mass-produced using *E. coli* or other prokaryotic

expression systems. I shall not go into details, but currently, the production of FGFC protein in labs is done using the *E. coli* equipped with T7 bacteriophage and a plasmid vector called pET-3c. This protein expression system is a type called “*E. coli* hijacking system,” and while it is widely used around the world, I was lucky that I received and was able to actually use the materials and information early from the researcher who developed this system. Using this system, it became possible from the early stages to prepare the recombinant protein in the lab, at the scale of several ten to several hundred times more than the conventional recombinant protein expression method. Therefore, it was possible to produce large amounts of various FGFCs and to conduct various analyses for their activities and properties.^{[11][12]}

7.3 Rediscovery of FGFC efficacy from the receptor bond specificity

By analyzing the responsivity of various FGFCs using various cultured cell types, we were able to select the few types that showed characteristic properties and bioactivity. For some molecules, we found that there was high activity

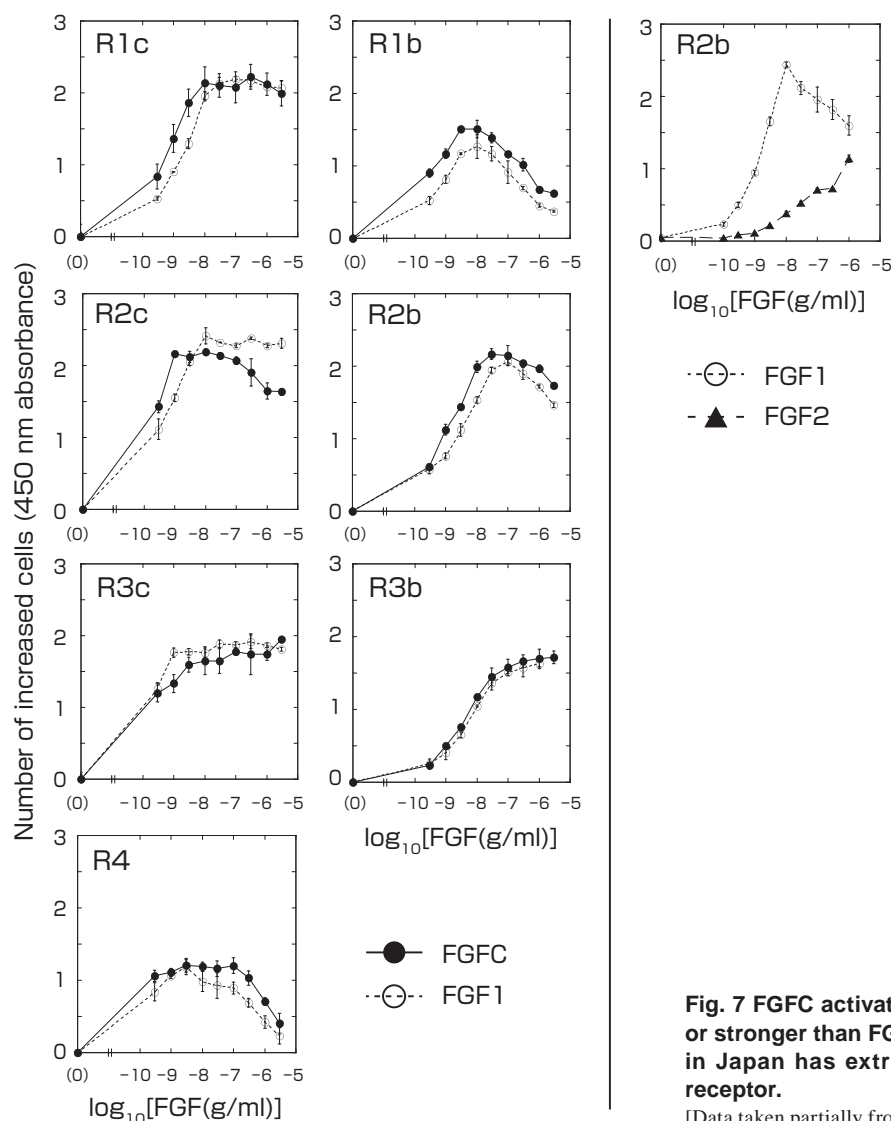

Fig. 7 FGFC activates all types of FGF receptors equally or stronger than FGF1. The FGF2 that is a drug approved in Japan has extremely low activity against the R2b receptor.

[Data taken partially from Motomura *et al.*, *BBA* (2008)]

without dependence on heparin. These molecular structures were the basic form of the stabilized FGF with a specific structure that we call FGFC today.

When a cell detects FGF on its surface, there is an involvement of a transmembrane protein called the tyrosine kinase receptor, and the extracellular part of the receptor specifically detects and binds with the FGF molecule. Then the enzyme tyrosine kinase resides in the intracellular component of the receptor becomes activated. The tyrosine kinase FGF receptor transmits the presence of extracellular FGF as an intracellular signal. To describe the FGF activity precisely in the molecular level, it is necessary to manipulate the receptors experimentally. There are four types of tyrosine kinase FGF receptor genes, and these genes code the total seven main types of FGF receptor proteins. Therefore, a cell based screening system was created to analyze the signaling by each receptor. As a result of analyzing the receptor specificity using this experimental system, we were surprised to find that the basic FGFC possesses the ability to activate all seven types of FGF receptor proteins to the same degree or slightly stronger than FGF1. This is a property unseen in other natural form FGFs (Fig. 7).^[13]

On the other hand, the bioactivity of a basic FGFC was the same as FGF2 in the property that it was not influenced greatly by the coexistence of heparin sugar chain. Next, we investigated the stability of the three-dimensional structure of the protein needed to express the FGF activity, using the melting point. It was found that in the condition of the investigation, the melting point of the basic FGFC was about five degrees higher than FGF1. From these results, it was strongly suggested that the basic FGFC has higher stability than FGF1 and has a superior property as a pharmaceutical compound.

7.4 Optimization of the FGFC structure with an eye on pharmaceutical use

It was found that the basic FGFC had a wide range of specific bioactivity, was also stable, and this molecule was an excellent candidate for pharmaceutical use. We attempted

further optimization of the molecular form. That is, the optimization of the fine structures were done for the purpose of two objectives: minimizing the antigenicity against humans that could not be pursued earlier for the FGFC molecular group created earlier due to the technological limitations at the time, and optimizing the resistance to protein dissolving enzymes. In the initial molecular form, the recognition sequence of the limiting enzyme was introduced to the gene to maintain the seam for chimerization, and there was a concern for the antigenicity against humans as partial amino acid replacement could not be avoided. However, in the current molecular engineering, the amino acid sequence can be designed freely, and therefore we fabricated several types of molecules using the primary structure of the prototype FGFC as a base, and, for example, eliminated the amino acid sequence other than those of FGF1 or FGF2. In this maneuver, we selected a molecule with the highest resistance to the degradation by proteolytic enzymes. This is the current FGFC. Thus, FGFC of optimized molecular structure with an eye on pharmaceutical use was established (Fig. 8).^{[13]-[15]} In this paper, this molecule will be called FGFC.

In the sequence of this FGFC, there is no amino acid introduced artificially to chimerize the two types of proteins that originally exist in humans. Therefore, the antigenicity when it is administered to humans is expected to be minimal, but the actual antigenicity test has not been done. This test will be conducted as one of the items of the safety tests.

8 Large potential of FGFC as a radioprotective drug candidate

8.1 Protection of intestinal damage (prevention through preliminary administration)

One of the major causes of life threatening damage by high-dose radiation is the loss of intestinal function due to the death of the stem cell clusters (crypts) in the intestinal mucosal cells. This is because the intestinal tracts maintain its structure and function by supporting the cell metabolism through incessant regeneration of the cells. As mentioned

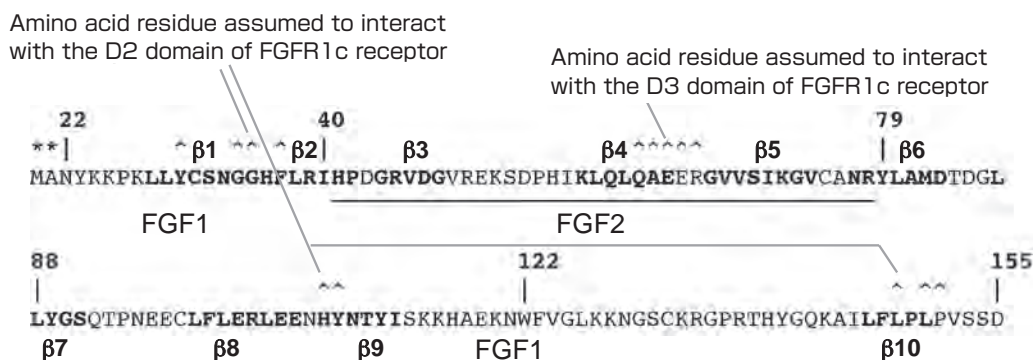

Fig. 8 Primary structure of FGFC

The structure is composed of the sequences derived from FGF1 and from FGF2.

earlier, FGF1 had the highest radioprotective effect among the natural form FGFs. Therefore, the protective action of FGF1 and FGFC were compared. The experimental mice were peritoneally administered either of the FGFs, 10 Gy of gamma ray was irradiated 24 hours later, and the number of live cells in the crypt was counted 3.5 days after. As a result, the FGFC administered group showed significantly higher number of cells compared to the FGF1 administered group. Of course, it was much higher than the control group that was not administered any drug. Therefore, it was shown that the FGFC was superior to FGF1 in the protective action against intestinal radiation damage (Fig. 9 left).^[15]

That was not all. Since the bioactivity of FGF1 necessitated the presence of heparin and the molecular structure of FGF1 became stabilized in the presence of heparin, we normally employed the protocol of administering the FGF1 and heparin simultaneously. However, in the case where the intestinal tracts were damaged significantly by radiation and were prone to hemorrhage, the co-administration of heparin that inhibits blood coagulation was not preferable. Therefore, the radiation damage was evaluated under the condition of not using heparin. As a result, it was shown that FGFC

showed strong radioprotective action without the presence of heparin (Fig. 9 right).^[15]

8.2 Protection of intestinal tract damage (treatment by post facto administration)

When using protective drugs against high-dose radiation, most cases will be administration of a protective drug after exposure (*post facto* administration). However, in reality, there are hardly any biological radioprotective drugs that produce effects in that manner of administration.

We analyzed the effect of *post facto* administration of FGFC from the aspect of protection against intestinal tract damage. FGFC was administered 24 hours after exposure to strong radiation of 10 Gy, and the growth of the intestinal crypt cells were investigated. It was shown that many cells showed growth response. This indicated that FGFC promoted growth in the few intestinal stem cells that survived the damage of radiation (Fig. 10).^[15]

8.3 Protection against individual death (preventive or post facto administration)

The exposure to high-dose radiation may result in the death

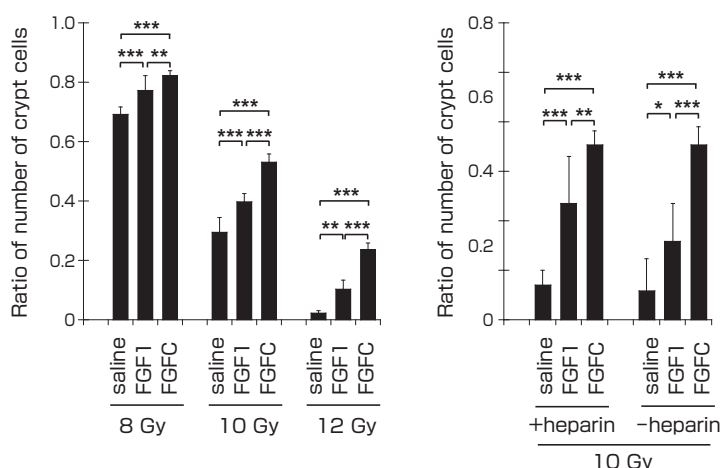

Fig. 9 Radiation damage of the intestinal tract is reduced when FGFC is administered before exposure. This activity is stronger than FGF1 in a wide range of radiation doses, and the difference becomes more apparent when heparin is not co-administered.

[Data taken partially from Nakayama *et al.*, *IJORBP* (2010).]

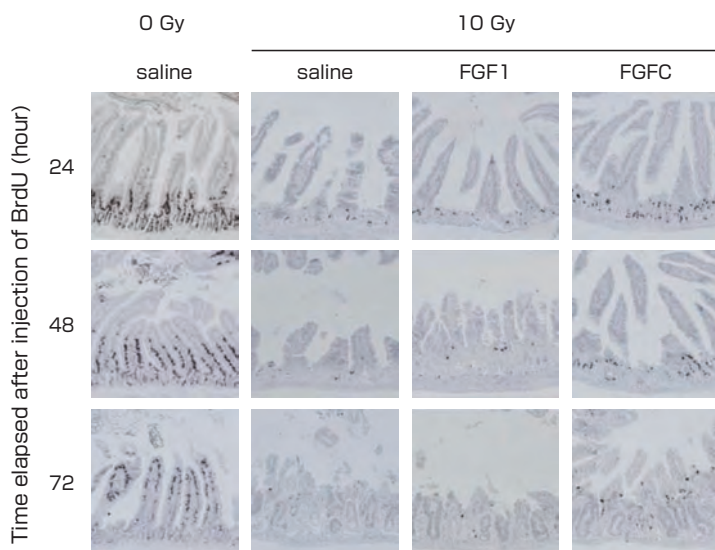

Fig. 10 The surviving cells in the intestinal epithelial stem cell niche shows proliferative response when FGFC is administered 24 hours before exposure. The photographs are cross sections of the villi that are formed by the intestinal epithelial cells. The epithelial stem cells exist in the basal part between the villi. In this experiment, the proliferating cells are stained dark brown, indicating that they are reproducing.

[Data taken partially from Nakayama *et al.*, *IJORBP* (2010).]

of the individual. Therefore, the most significant evaluation standard of radioprotective action can be considered the suppression of individual deaths. We obtained results that when FGFC alone was administered before exposure, the survival time until individual death can be significantly extended (Fig. 11).

Moreover, even when FGFC alone was administered after exposure, it was indicated that the survival time might be extended. In fact, the emergency treatment in case of high-dose exposure is not the use of radioprotective drugs alone, but multiple measures are combined. Therefore, the aforementioned life extending effect by FGFC may be further enhanced by a combination of protective drugs other than FGFC or stem cell/bone marrow transplants. Therefore, the ways of combining and the evaluation of efficacy will be future R&D topics.

8.4 Mechanism of radioprotection (preventive administration)

Then, what is the mechanism that brings about the radioprotective effect of FGFC? In general, the molecular mechanism of the action of biological radioprotective drugs has not been clarified sufficiently. First, we analyzed how apoptosis (programmed cell death) of the crypt cells was affected after radiation exposure when FGFC was administered before radiation exposure. As a result, when the two indices that indicated apoptosis were investigated, it was found that apoptosis was inhibited in the group that received preventive administration of FGFC (Fig. 12).^[15]

8.5 Mechanism of radioprotection (post facto administration)

How is the protection effect expressed in the case where FGFC was administered after radiation exposure? If the exposure occurs without protection, cell death occurs and the damage is irreversible. The growth and differentiation of the intestinal epithelial cells was investigated in animals where efficacy

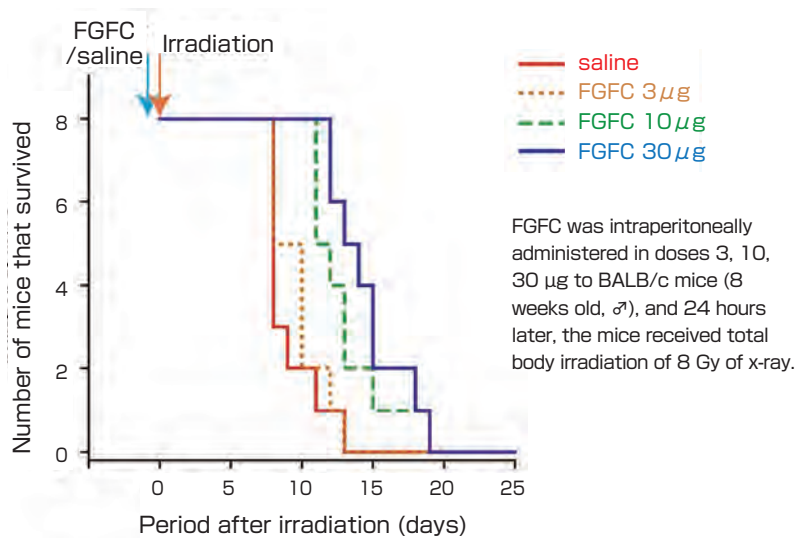

Fig. 11 The individual death after exposure is reduced and the survival period is increased when FGFC is administered before exposure.

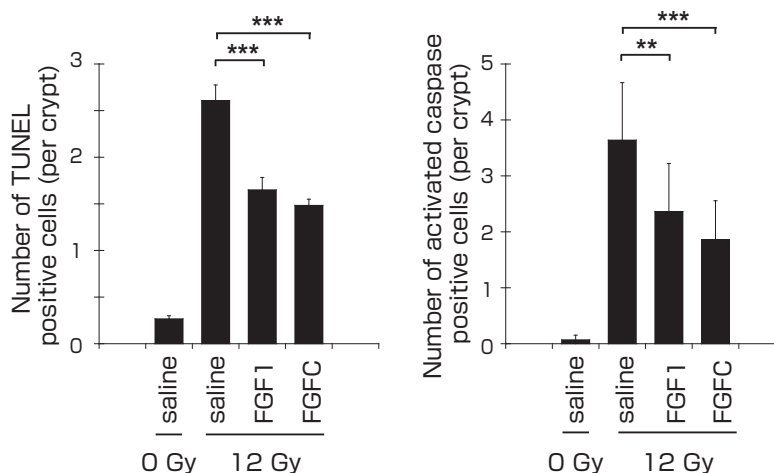

Fig. 12 It was shown that cell death was inhibited when FGFC was administered before exposure, according to both index A that indicates programmed cell death (left: TUNEL) and index B (right: activated caspase 3).

[Data taken partially from Nakayama *et al.*, *IJORB* (2010).]

was confirmed in the *post facto* administration of FGFC after 24 hours. As a result, as mentioned in subchapter 8.2, the proliferative response of the crypt cells was confirmed. It was also shown that for the epithelial cells that possess the function of intestinal villi that occur through the growth and differentiation of the crypt cells, the expression of such growth and differentiation markers increased with the administration of FGFC (Fig. 13).^[15] Therefore, it is thought that both the growth differentiation of the differentiated stem cells and the promotion of proliferation of surviving stem cells are promoted by FGFC.

Acknowledgements

In this paper, the current situation where the radioprotective drug is about to be born through the combination of the outcomes of several basic and project researches was summarized. These outcomes were attained by the works of a number of researchers. I shall list the people who directly contributed to the results described in this paper (in order of appearance in the paper; order within the item is random). Also, this research was made possible through peripheral disciplines supported by many people. I am deeply thankful to all people involved. (Honorifics abbreviated; organizations listed are those to which the researchers belonged during the research; people without organization listing belonged to the Agency of Industrial Science and Technology or AIST).

- PG-FGF1: Atsuko Yoneda, Masahiro Asada, Yuko Oda, and Keiko Ohta
- FGFC: Thomas Maciag (deceased; American Red Cross), John Anthony Thompson (Alabama University), Yoshihito Tokita, Kaori Motomura, Emi Honda, and Tadanori Tanahashi
- Protein expression system: Alan Rosenberg (Brookhaven National Laboratory)

- Cell analysis system: Masashi Suzuki, Masahiro Asada, Emi Honda, Junko Oki, Akiko Kuramochi, Yuriko Uehara, Miho Ueki, Nozomi Tsujino, Atsuko Yoneda, and David Ornitz (Washington University)
- Sendai virus vector: Mahito Nakanishi and Hiroaki Segawa
- Analysis of radioprotective effect: Masahiro Asada, Junko Oki, Megumi Goto, Akiko Hagiwara, Fumiaki Nakayama (National Institute of Radiological Sciences; Associate Researcher, AIST), Makoto Akashi (NIRS; Associate Researcher, AIST), Misawo Hachiya (NIRS), Sadako Umeda (NIRS), and Takashi Imai (NIRS; Associate Researcher, AIST)

Research Projects

1991~2000 (10 years)

Development of Core Technology for Next Generation Industry

“Development of technologies for the production and utilization of complex carbohydrates: Production of complex carbohydrates using animal cells”

2005~2009 (5 years)

R&D in the Nuclear Energy Field, MEXT

“Research for the cell growth factor for the prevention and treatment of biological damage by radiation exposure and its application technology”

2005~2008 (2 years, 10 months)

Challenging Issue Research, Signaling Molecules Research Laboratory

“Core research for signaling molecules”

2011~2012 (1 year)

Strategic Research “Development of a radioprotective drug”

2013~2015

Strategic Research “Development of technology to reduce side effects of cancer radiotherapy”

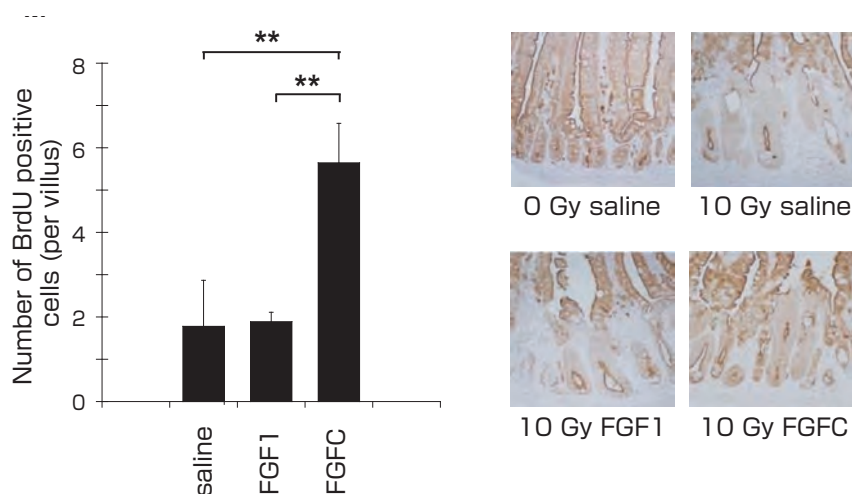

Fig. 13 It can be seen that the proliferation (left: evaluated as number of BrdU positive cells per villus) and differentiation (right: brown stain of villus differentiation marker) of the intestinal villi cells were promoted when FGFC was administered 24 hours after exposure.

[Data taken partially from Nakayama *et al.*, *IJORB* (2010).]

References

- [1] A. Hagiwara, F. Nakayama, K. Motomura, M. Asada, M. Suzuki, T. Imamura and M. Akashi: Comparison of expression profiles of several fibroblast growth factor receptors in the mouse jejunum: Suggestive evidence for a differential radioprotective effect among major FGF family members and the potency of FGF1, *Radiat. Res.*, 172 (1), 58-65 (2009).
- [2] A. Yoneda, M. Asada, Y. Oda, M. Suzuki and T. Imamura: Engineering of an FGF-proteoglycan fusion protein with heparin-independent, mitogenic activity, *Nature Biotech.*, 18 (6), 641-644 (2000).
- [3] A. Yoneda, M. Asada and T. Imamura: Shindekan to no yugo ni yoru heparin ketsugosei zoshoku inshi FGF-1 no kassei kaihen (Changes in action of FGF-1, a heparin-bonded growth factor, by fusion with syndecan), *Saibo Kogaku*, 19 (9), 1338-1340 (2000) (in Japanese).
- [4] M. Asada, A. Yoneda and T. Imamura: Engineering of a heparin-binding growth factor with heparan sulfate sugar chains, *Trends Glycosci. Glycotech.*, 13 (72), 385-394 (2001).
- [5] T. Imamura, M. Asada, S. Oka, M. Suzuki, Chie Asada/Matsuda, A. Yoneda, K. Ota, Y. Oda, K. Miyakawa, N. Oriyasa and T. Kojima: Japan Patent No. 3318602 "Tosafuka-gata heparin ketsugosei tanpakushitsu, sono seizo hoho oyobi sore o gan'yusuru iyaku soseibutsu (Heparin-binding proteins modified with sugar chains, method of producing the same and pharmaceutical compositions containing the same)," Filed November 10, 1997, Date of Patent June 21, 2002 (in Japanese).
- [6] T. Imamura, M. Asada, S. Oka, M. Suzuki, A. Yoneda, K. Ota, Y. Oda, K. Miyakawa, N. Oriyasa, C. Asada/Matsuda and T. Kojima: US Patent No. 7005415 "Heparin-binding proteins modified with sugar chains, method of producing the same and pharmaceutical compositions containing the same," Filed July 22, 1998, Date of Patent February 28, 2006.
- [7] T. Imamura, M. Asada, S. Oka, M. Suzuki, C. Asada/Matsuda, A. Yoneda, K. Ota, Y. Oda, K. Miyakawa, N. Oriyasa and T. Kojima: US Patent No. 7282481 "Heparin-binding proteins modified with sugar chains, method of producing the same and pharmaceutical compositions containing the same," Filed November 23, 2005, Date of Patent October 16, 2007.
- [8] T. Imamura, A. Asada and M. Suzuki: UK Patent No. 2427863 "Heparin-binding protein modified with heparan sulfate sugar chains, process for producing the same and pharmaceutical compositions containing the same," Filed March 31, 2005, Date of Patent December 17, 2008.
- [9] T. Imamura, A. Asada and M. Suzuki: Japan Patent No. 4505631 "Heparan ryusan tosa o fukashita heparin ketsugosei tanpakushitsu, sono seizo hoho oyobi sore o gan'yusuru iyaku soseibutsu (Heparin-binding protein modified with heparan sulfate sugar chains, process for producing the same and pharmaceutical compositions containing the same)," Filed March 31, 2004, Date of Patent May 14, 2010 (in Japanese).
- [10] T. Imamura, A. Asada and M. Suzuki: US Patent No. 7741078 "Heparin-binding protein modified with heparan sulfate sugar chains, process for producing the same and pharmaceutical compositions containing the same," Filed March 31, 2005, Date of Patent June 22, 2010.
- [11] T. Imamura, S. A. Friedman, S. Gamble, Y. Tokita, S. R. Opalenik, J. A. Thompson and T. Maciag: Identification of the domain within fibroblast growth factor-1 responsible for heparin-dependence, *Biochim. Biophys. Acta*, 1266 (2), 124-130 (1995).
- [12] T. Imamura and S. Oka: Japan Patent No. 2733207 "Sen'iga saibo seicho inshi chimera tanpakushitsu o gan'yusuru iyaku soseibutsu (Pharmaceutical composition containing chimera protein, a fibroblast growth factor)," Filed May 18, 1995, Date of Patent November 26, 1996 (in Japanese).
- [13] K. Motomura, A. Hagiwara, A. Komi-Kuramochi, Y. Hanyu, M. Suzuki, M. Kimura, J. Oki, M. Asada, N. Sakaguchi, F. Nakayama, M. Akashi, E. Honda and T. Imamura: An FGF1:FGF2 chimeric growth factor exhibits universal FGF receptor specificity, enhanced stability and augmented activity useful for epithelial proliferation and radioprotection, *Biochem. Biophys. Acta*, 1780 (12), 1432-1440 (2008).
- [14] T. Imamura, K. Motomura, A. Kuramochi, Y. Hanyu, M. Suzuki, M. Asada, A. Hagiwara, F. Nakayama and M. Akashi: Japan Patent No. 5004250 "Kokinoka kimera tanpakushitsu o gan'yusuru iyaku soseibutsu (Pharmaceutical composition containing high-functionality chimera protein)," Filed October 10, 2008, Date of Patent June 1, 2012 (in Japanese).
- [15] F. Nakayama, A. Hagiwara, S. Umeda, M. Asada, M. Goto, J. Oki, M. Suzuki, T. Imamura and M. Akashi: Post treatment with an FGF chimeric growth factor enhances epithelial cell proliferation to improve recovery from radiation-induced intestinal damage, *Int. J. Radiat. Oncol. Biol. Phys.*, 78 (3), 860-867 (2010).

Author

Toru IMAMURA

Completed the doctorate course at the Graduate School of Pharmaceutical Sciences, The University of Tokyo in 1984 (Doctor, Pharmaceutical Sciences). Joined the Fermentation Research Institute, Agency of Industrial Science and Technology, Ministry of International Trade and Industry in 1984. Leader, Cell Function Laboratory, Biosignaling Department, National Institute of Bioscience and Human Technology, Agency of Industrial Science and Technology in 1996; Vice Director, Gene Discovery Research Center, AIST in 2001; Vice Director, Age Dimension Research Center; Director, Signaling Molecules Research Laboratory in 2005; Vice Director, Neuroscience Research Institute; and Group Leader, Signaling Molecule RG, Biomedical Research Institute in 2010 to present. Also Visiting Researcher, American Red Cross Jerome H. Holland Laboratory for the Biomedical Sciences, USA; Adjunct Professor, Tokyo University of Science; CTO, Advangen, Inc.; and Professor, Tsukuba University. Received the Tsukuba Encouragement Award in 1996; and the Pharmaceutical Society of Japan Award for Divisional Scientific Contributions in 2013. Engages in research with focus on cell growth factor FGF for vascular endothelial cell, hepatic cell, receptor, complex carbohydrates, high order function of nervous system, muscle differentiation, dermal homeostasis and hair growth control, and protection against radiation damage.



Discussions with Reviewers

1 Title

Comment (Yoshiho Hino, Former Evaluation Department, AIST)

The title suggestion “Development of technology to reduce the biological damage by ionizing radiation” is very attractive, but I fear that it might give too much expectation to readers.

Answer (Toru Imamura)

I suggested this title from the perspective of having a simple title that can be readily accepted and understood by the readers outside the life science field. Since I received your comment that it may encompass too much, I shall use the main title and the subtitle that presents the characteristic of the scenario as follows:

Title “Development of a stable growth factor suitable for radioprotection”

Subtitle “Drug development-aimed R&D at a basic research institute”

2 Description of the scenario

Comment (Motoyuki Akamatsu, Human Technology Research Institute, AIST)

This is a paper on the scenario for sending out FGF to society as a radioprotective drug. I think the scenario and the work based on it will be useful for readers, even if the drug itself has not yet been achieved. Since the scenario for sending the general drug out to society and the scenario for a radioprotective drug are different, I think you will be able to draw the readers’ attention further if you emphasize the scenario that is unique to radioprotective drugs.

Also, I get an impression that the relationship between PG-FGF1 and FGFC is unclear. If you have multiple scenarios running concurrently, please consider explaining this by using a diagram of the scenario.

Comment (Noboru Yumoto, AIST)

The objective of this research is the “development of a new radioprotective drug that possesses activity that surpasses the current drugs.” Particularly for FGFC, the central focus is on the discovery of excellent properties as a drug such as “having high activity independent of heparin” and “possessing higher stability than FGF1,” the elemental technologies such as “establishment of a mass production system” and “optimization of the molecular structure with an eye on pharmaceutical use” are integrated, and the protective action against intestinal tract damage and individual death is demonstrated through animal experiments. However, while PG-FGF1 is a unique molecule, there are still issues in the “quality control” and the “establishment of a mass production system” needed for drugs. Therefore, in this paper, I think you should focus on the results of FGFC, and keep the reference to the results of PG-FGF1 to a minimum if addressed at all.

Answer (Toru Imamura)

Thank you very much for understanding the significance of the research and the scenario. Based on your suggestion, I described the point that the scenarios to send products out to society differ for general pharmaceuticals and radioprotective drugs.

PG-FGF1 and FGFC are in the midst of concurrent development processes, but PG-FGF1 is way too advanced and its road to product realization is distant, and the road to product realization can be seen only for FGFC currently. Therefore, I focused mainly on the description of FGFC in this paper. However, if products from both molecules are assumed in the future, I believe PG-FGF1 will be a better product. In other words, the FGF drug that is currently available on the market can be considered first generation, FGFC will be second generation, and PG-FGF1 will be third generation.

3 Process to pharmaceutical approval

Comment (Yoshiho Hino)

In establishing the medical drug production system aiming at obtaining approval, it is needed to do the safety test and efficacy test, but this is described in such general terms, and it is not clearly or specifically described who does what.

Answer (Toru Imamura)

This research has difficult issues common to drug discovery oriented research at AIST. The substance for which drug discovery development is being done is thought to be one of the closest to exit among the intellectual properties of AIST.

To develop a drug at AIST alone all the way to the final phase is impossible in terms of funding and organization. However, even if we engage in “R&D that disregards the manner of drug discovery,” it will not be a true *Type 2 Basic Research* that leads in to *Product Realization Research*. There are strict screenings before a substance with a novel effect is approved as a drug, and I think the role of *Type 2 Basic Research* in the drug discovery at AIST is to create the foundation for withstanding such screening. Here, the “safety test and efficacy test are described in general terms,” but please understand that there are many development elements and difficulties in conducting such tests. Considering your indication, I eliminated a large part on the establishment of a production system and a safety test, and kept their descriptions brief.

4 Overall structure of the paper

Comment (Noboru Yumoto)

As stated in the subtitle “Drug development-aimed R&D at a basic research institute,” there are three parts to the drug discovery process: 1) a part that can be done mainly at basic engineering research institute such as AIST, 2) a part that can be done collaboratively at medical institution and company, and 3) a part that can be done mainly at pharmaceutical company. In this paper, about 1) and 2), the focus is on the result, while with 3), the process is described in chapter 8. However, I think the description centering on the results makes this paper suitable for *Synthesiology*. Considering the readers who are not knowledgeable about the drug discovery process, I think you should explain in detail the overall structure of the scenario at the beginning of the paper, and make clear that you are describing the results of 1) and 2) in this paper. With the current description, the readers who started to read the paper expecting some results for a radioprotective drug, which currently is drawing a lot of attention, may end up with the impression that it is far from practical use. By clarifying the part that can be done at a basic research institute, I think you can give a positive impression that so much has been accomplished.

Also, I think whether you develop a radioprotective drug or whether you develop a drug to mitigate the side effects of cancer therapy require different scenarios. Since the description of a scenario is important for a *Synthesiology* paper, please describe from what perspective you changed the scenario.

Answer (Toru Imamura)

As you indicated, considering the readers who are not familiar with the drug discovery process, I changed the structure of the paper to carefully explain the scenario in the beginning using Fig. 2. To do so, the items were rearranged, and the positioning of this subject in *Synthesiology* was stated in chapter 1 “Introduction,” the introduction to radioprotective drugs was given in chapter 2, and the scenario and the synthesis method, as well as the reason for developing the drug to mitigate the side effects of cancer therapy was explained in chapter 3.

5 Internal and external exposure

Comment (Yoshiho Hino)

The FGF drugs originally assume high-dose radiation of “external exposure,” and I am not sure whether you need to mention “internal exposure.” In general, for internal exposure, there is a possibility that the damage may occur due to the “cumulative effect over a long time,” and the causative substance must be excreted from the body by other processes. Please describe clearly to what level of exposure this currently developed FGF drug is effective.

Answer (Toru Imamura)

I added an explanation that clarifies the range of the developed drug in Fig. 1.

For internal and external exposure, the descriptions are left as is because the biological effect will occur in the case of internal exposure by a radioactive substance that emits strong gamma rays, and the mechanism is the same as high-dose external exposure. For the damage by internal exposure, the in-depth discussion of the heterogeneity of biological damage caused by alpha and beta rays was avoided in this paper.

Development of a protein array for autoantibody profiling of blood

— Comprehensive disease diagnosis using the body's defense system —

Yoshitaka KAWAKAMI¹ and Naoki GOSHIMA^{2*}

[Translation from *Synthesiology*, Vol.7, No.3, p.154-162 (2014)]

We have developed infrastructure of the technologies and resources for post-human genome research to perform functional proteomics (the analysis of protein functions, protein-protein interactions, and human protein structures) on a large scale. A method for profiling autoantibodies in serum is developed using human protein expression resources and protein expression techniques. The human biological defense system responds to abnormalities in the body with extraordinary sensitivity. Hence, this system is an effective tool for detecting human diseases at an early stage. Health safety and security can be achieved by establishing an early diagnostic method for diseases using autoantibody profiling of blood with a protein array.

Keywords : Autoantibody, protein array, human protein, body's defense system, antigens, diagnosis, biomarker

1 Introduction

The ability to diagnose a disease before its development or at an early stage and obtaining a general diagnosis in which as much health information can be obtained in a single test is an extremely important issue in achieving a safe and secure society. In this research, we aim to achieve this objective by analyzing the types and quantities of autoantibodies in one drop of blood. Originally, the antibody is a biological defense system acquired by higher-order organisms through evolution, to defend themselves against bacteria and virus invasions. The antibody system is known to produce autoantibody against its own protein in response to the abnormal release of protein from cells or to the excessive production of proteins due to disease, as well as against external antigens. We think it is reasonable to utilize the biological defense mechanism that responds sensitively to the abnormalities of the body to detect diseases. Particularly, since the autoimmune diseases occur due to the production of antibodies that attack their own cells or tissues, the autoantibodies can be the cause of disease as well as disease markers. The detection of autoantibodies may enable presymptomatic testing for autoimmune diseases, thereby allowing early treatment. However, in practice, comprehensive tests for autoantibodies have not been established, and in most cases, one visits a hospital only after the symptoms of autoimmune diseases develop. There are also several intractable diseases in which the involvement of autoantibodies is suspected, and the development of a comprehensive detection system for autoantibodies is extremely important. There are many papers that reported the use of autoantibodies as disease markers for diseases

including diabetes, cancer, Alzheimer's disease, rheumatism, and dilated cardiomyopathy.^[1] We developed a comprehensive detection system of autoantibodies and have correlated the autoantibodies and diseases, by preparing antigen proteins using the world's largest human protein expression resource and a human protein synthesis technology that we have been working on for a long time. We hope to further the technological development for a comprehensive profiling of blood autoantibodies that are individually different and are closely related to health.

2 Construction of a human protein expression resource and its use

Based on the human full-length cDNA sequencing project of the Ministry of International Trade and Industry (currently Ministry of Economy, Trade and Industry) that was started in 1998, we started preparations for the following in the Protein Function Analysis Project of the New Energy and Industrial Technology Development Organization (NEDO) in 2000: (1) Human Proteome Expression (HUPEX) resource, (2) high-throughput protein synthesis technology, and (3) Human Gene and Protein Database (HGPD). At the time, the Human Genome Project to decode the genome DNA sequence was being done internationally, and taking the lead for the coming age of proteomics, Japan decided to fortify the environment for human genome research, constructed the HUPEX resource, and built a database.^{[2][3]} The preparations of the technological foundation to carry out large-scale analyses of human protein functions, protein interactions, and protein structures were conducted as national projects. As a result, the HUPEX resource was utilized in various national research

1. Japan Biological Informatics Consortium TIME24 Bldg. 10F, 2-4-32 Aomi, Koto-ku 135-8073, Japan, 2. Molecular Profiling Research Center for Drug Discovery, AIST 2-4-7 Aomi, Koto-ku 135-0064, Japan * E-mail: n-goshima@aist.go.jp

Original manuscript received July 17, 2013, Revisions received January 27, 2014, Accepted January 27, 2014

projects, joint research with corporations, and academic joint researches with research institutes and universities, and yielded rich results in the respective fields. One of the major results was a joint project “Special Project for Yamanaka iPS Cell” of the Japan Science and Technology Agency (JST) with Dr. Shinya Yamanaka, Director of the Center of iPS Cell Research and Application (CiRA), Kyoto University. This project led to the new discovery of Glis1, a gene for promoting the induction of iPS cells.^[4] Moreover, in the joint research with the School of Medicine, Gifu University, a factor to highly efficiently induce iPS cells was discovered from the dental pulp cells in teeth. In the joint study with the School of Medicine, Keio University, a factor to promote direct reprogramming where the myocardial cells can be made from heart fibroblasts was discovered. Many results were obtained in the search for factors that may be useful in regenerative medicine. Also, major results were obtained in the development of *in vitro* visualization technology of protein interaction for a drug discovery screening system, and the development of production of standard proteins for quantitative proteomics by mass spectrometer. Such research results were expected in the initial conceptualization of the HUPEX resource uses. The HUPEX resource technology that we have constructed so far was basically to support the smooth progress of industrial proteome research. Sometimes, as we

deepen our research in a discipline, new horizons that we did not initially consider begin to unfold. When we climbed the mountain of the proteome study and looked back, we realized that we could study the comprehensive antibody fields when the protein groups that comprise the proteome are considered as antigens. As shown in Fig. 1, we could study the immunome (whole immune system) from the proteome (while not all antigens are proteins, they comprise a major part). The idea of comprehensively analyzing the autoantibody in blood using the HUPEX resource and applying it in diagnosis (Fig. 2) was not considered initially. However, we were capable of using more human proteins as antigens than any other researcher in the world, and we possessed the ability to use the resource to find out whether the antibodies are present in the blood serum. Many researchers have previously reported the idea of using the autoantibodies in the blood serum.^[1] However, since it was difficult to prepare the antigens to detect the antibodies, comprehensive analysis of autoantibody had not been done until now. Currently, we are able to conduct the world’s most accurate profiling of the blood serum autoantibody using the HUPEX resource. To realize autoantibody profiling, in addition to the HUPEX resource, it was necessary to establish a comprehensive protein expression technology, a technology for manufacturing protein arrays, and an antibody detection method. These technologies will be explained below.

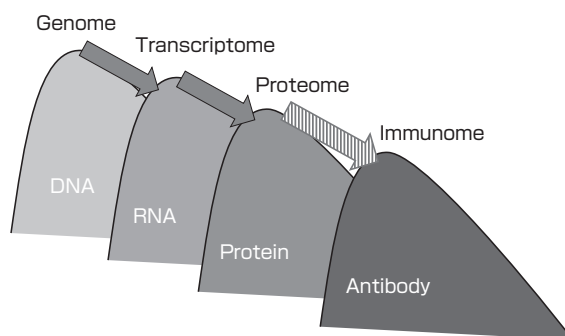

Fig. 1 From proteome to immunome

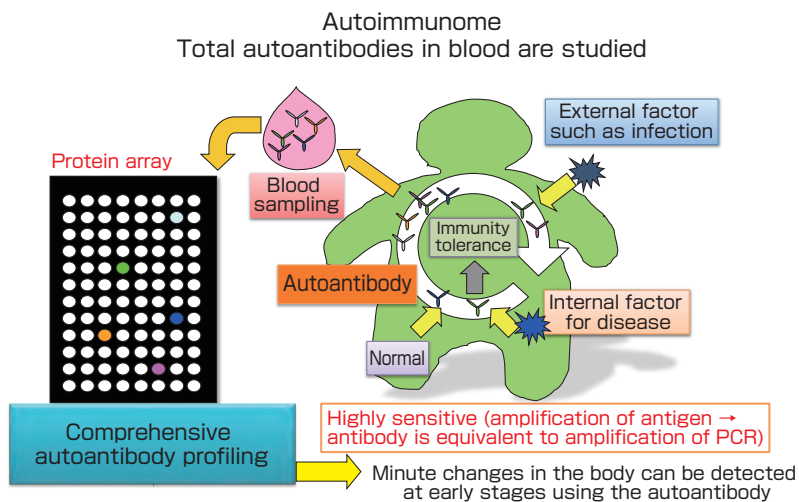

Fig. 2 Autoantibody and disease

3 Development of a protein array that allows autoantibody profiling

3.1 Comprehensive human proteome expression resource and protein expression technology

We constructed a protein expression resource by introducing the Gateway cloning technology, a general-use cloning system, and created the plasmid DNA (entry clone) with site-specific recombination sequence at both ends of the open reading frame (ORF) of cDNA.^[2] In the Gateway cloning technology, the expression clone can be created simply by mixing the entry clone and the destination vector, and by conducting site-specific DNA recombination using the recombination enzyme in a test tube. This is an optimal DNA recombination technology when conducting high-throughput protein expression.^[5] This resource is the world's largest protein expression resource that covers about 80 % of the human genome,^[2] and is named the HUPEX resource. Two types of entry clones were created: the N-type entry clone where the same amino acid sequence can be synthesized as the native protein at the C terminal per cDNA; and the F-type where the stop codon is replaced with a sense codon so a tag can be attached to the C terminal.^[6] Various types of ORF type entry clones were created including the full-length ORF type with whole ORF for the gene, processing ORF type where the signal peptides were eliminated from the full-length ORF, and the domain ORF that could express the extracellular domain or intracellular domain with membrane protein with single membrane penetration domain. These resources can be freely selected according to the research objective. Also, since the protein synthesis can be conducted with all types of protein synthesis systems, the SD (Shine-Dalgarno) sequence for *E. coli* expression and Kozak sequence for eukaryotic cell expression was added to the 5' upstream of ORF. For these protein expression resources, the N-type and F-type entry clones were prepared, and about 60,000 types were created including the known and unknown clones, as well as the splicing variant clones (Table 1). To use these entry clones in a comprehensive proteome research, a clone with the longest ORF is selected for each gene as a representative clone, and they are functionally categorized

Table 1. Number of manufactured Gateway entry clones

Type	Determined number of entry clones	
	C terminal stop	C terminal fusion
Full-length ORF	18,744	28,386
Processing ORF	4,068	2,863
Domain ORF	2,719	-
Total	25,531	31,249
	56,780	

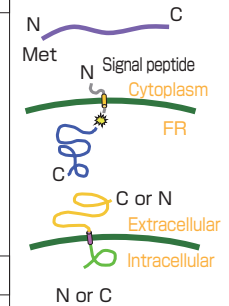

according to the functions of proteins (transcription factor group, GPCR group, kinase group, unknown gene group, etc.). About 20,000 clones representing human genes were used in our research.

To conduct the comprehensive proteome research using human proteins, the technology to comprehensively synthesize the protein is necessary, as well as building the HUPEX resource. Around the year 2000 when we started constructing the protein expression resource, at the same time, Professor Yaeta Endo *et al.* of the Ehime University developed a wheat germ cell-free protein synthesis system.^[7] We developed the technology for high-throughput protein synthesis using the wheat germ cell-free protein synthesis system (Fig. 3). The wheat germ cell-free protein synthesis system was superior in the points of success rate of protein synthesis, solubilization rate of the synthesized protein, and activity maintenance rate of the synthesized protein compared to other protein synthesis systems using *E. coli* or eukaryotic cells, and the protein could be synthesized at the percentage of 98 % or higher.^[6] The whole reaction from DNA structuring to protein synthesis was done in an *in vitro* system (96 hole or 384 hole plate), and the reaction was optimized so only the dispensing procedure where the reacted solution was transferred to the next reaction solution was necessary. As a result, we developed a technology where the whole process of protein synthesis could be completed in

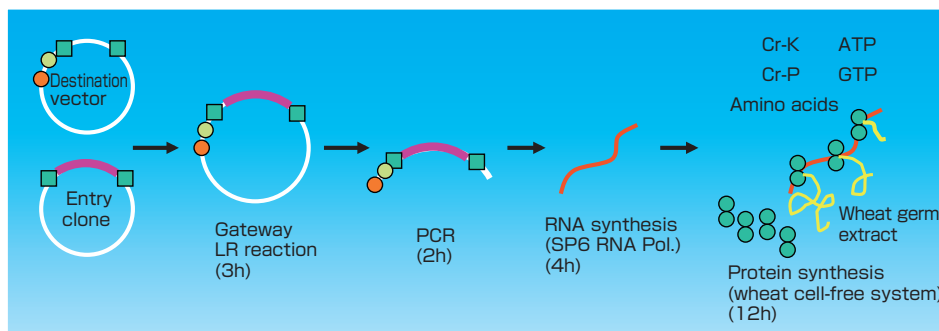

Fig. 3 Wheat germ cell-free protein synthesis system using the Gateway entry clone

Note) Modification of Fig. 6 in N. Goshima *et al.*: Constructing the foundation for comprehensive expression of human proteins, *Jpn. J. Exp. Med. (Extra no.)*, 23 (4), Chap. 3, Sec. 3, Yodosha (2005) (in Japanese).

one week. The LR product, PCR product, and mRNA that are created in the process of protein synthesis can be stored for a long period at -80 °C. In case it becomes necessary to resynthesize the same protein, it can be resynthesized in 18 hours using the stored mRNA. By combining the protein synthesis technology and a dispenser, it became possible to synthesize about 20,000 protein types at one time, and all proteins can be used in the simultaneous assay system through the array technology.

The results of the genetic information of the entry clones, the status of clones, and the results of protein expression of the wheat germ cell-free system or *E. coli* system are stored in the Human Gene and Protein Database (HGPD: <http://www.HGPD.jp/>), and they can be searched freely. The created entry clones are available from the National Biological Resource Center (NBRC), National Institute of Technology and Evaluation (NITE) (<http://www.nbrc.nite.go.jp/hgentry.html>).^{[3][8]}

3.2 Development of the protein array technology

The protein array technology is useful in comprehensively analyzing the interactions of protein-protein, protein-low molecule, protein-nucleic acid, etc., as well as for analyzing the enzyme-substrate protein. In a conventional protein array, the protein is fixed on the nitrocellulose membrane sheet, or on the surface of the slide glass coated or specially treated with nitrocellulose. Due to the nature of the fixing method, the protein is fixed in a dehydrated condition on

the substrate surface, and the three-dimensional structure is not maintained. Therefore, with the conventional array, the function of the fixed protein cannot be analyzed. We aimed to recreate and analyze the biological reaction on the array using the HUPEX resource and the high-throughput protein synthesis technology that we developed. For this purpose, it was necessary to find a way to fix proteins on the array substrate in a condition where the 3D structures were maintained and the proteins could express their functions on the array.

We developed a protein array where 3D structures and functions of the proteins were maintained. First, we focused on the protein refining technology using magnetic beads. By using our protein synthesis technology, the proteins can be synthesized with various tags attached. The target protein synthesized with tags can be easily refined using the magnetic beads with ligands. First, the target protein is bonded to the magnetic beads while maintaining the 3D structure at the time of synthesis. Normally, the protein bonded to the magnetic beads are eluted, recovered, and used, but we considered a way to create an array while maintaining the bond between the magnetic beads and the protein. A well plate for bonding with the magnetic beads was developed, and by combining the high-throughput protein synthesis technology and the protein refining and array technologies using the magnetic beads, we developed the technology for creating an array while maintaining the 3D structure of the protein (Fig. 4A). The protein array, in

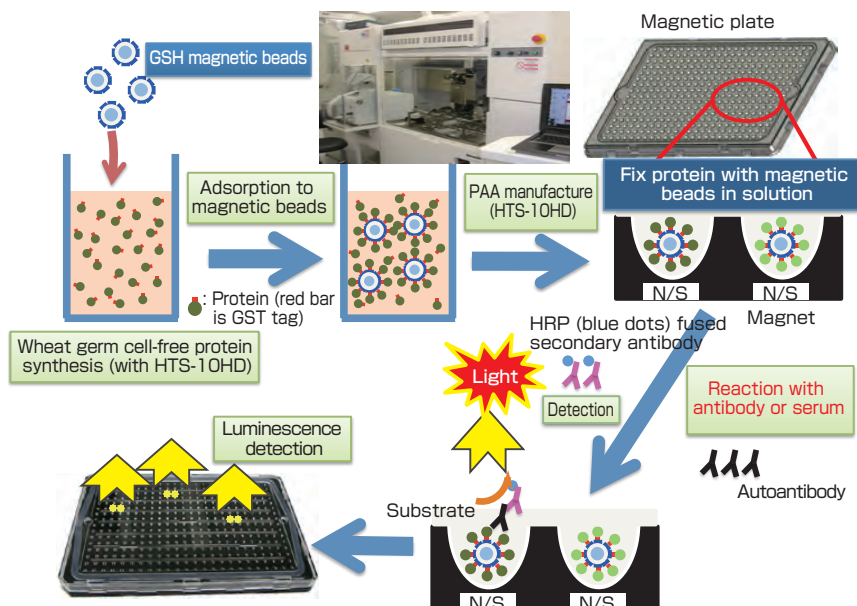

Fig. 4A Manufacture of protein active array using magnetic beads and antibody detection

The GST-fused target protein synthesized by the wheat germ cell-free synthesis system is attached to the GSH magnetic beads surface. This suspension is dispensed into the magnetic plate (originally made) equipped with magnets at the bottom of the plate, and the non-adhering fraction is removed by cleansing. The protein active array with protein fixed using the magnetic beads in the solution is manufactured. The antibody (Y) or blood serum is added to the protein active array (PAA), the protein is bonded onto the array, and the bonded antibodies are detected by chemiluminescence using the HRP-fused secondary antibody.

Note) Modification of Fig. 3 in N. Goshima: Autoantibody analysis using the array, *Handbook of Therapeutic and Diagnostic Antibodies*, Chap. 1, Sec. 5, NTS (2012) (in Japanese).

which the panoramic analysis of protein function for human proteome can be conducted, is called the “protein active array (PAA)” (Fig. 4B).

In selecting the magnetic beads used for the PAA, it is necessary to compare various magnetic beads from the following perspectives: 1) type of ligand of magnetic beads, 2) material and size of the beads, 3) amount of adsorbed target protein, 4) non-specific adsorption, and 5) method for dispensing the suspension. In general magnetic beads for His tag, GST tag, or Streptavidin tag adsorption are used. For the ligand of the magnetic beads, the GST tag adsorption magnetic beads was selected because the 5' FLAG-GST tag that allows creation of active expressed protein for protein synthesis was used. From the perspectives of aforementioned 2) to 5), we selected the glutathione particles of the MagneGST Protein Purification System (Promega Corporation).

When creating the PAA, a special well plate is necessary to which the magnetic beads bonded with expressed proteins can be fixed, and which does not require dispensers or other equipment when cleansing or supplying the common reagent. We developed a well plate for the PAA, where the magnet is installed at the bottom of the well and the thickness of the well bottom is made as thin as possible to allow the magnetic beads to bind strongly to the well bottom. Normally, in assays such as ELISA, each well uses independent plates, but for the magnetic beads array, the wells are designed to be independent of each other but the reaction of the solution made of diluted serum can take place without division between the wells. We also developed a special cover plate that prevents biohazards when handling the serum samples, and that allows the reaction to be accomplished with a small

amount of homogenous solution. By placing this cover plate, the target proteins on the surface of magnetic beads are covered with minute quantity of reaction liquid using a syringe, and the blood serum sample can be handled in a closed system rather than an open system.

By devising the equipment as described above, the manufacture process of the PAA can be accomplished very simply and in a short time. First, proteins synthesized by the wheat germ cell-free protein synthesis method using 96 well plates are added to the magnetic beads, and the proteins are bound to the surface of the magnetic beads. The suspension of the magnetic beads bound to proteins is dispensed to the well plate of the PAA, the proteins adhere to the well plate by magnetic force of the magnetic beads, and the array is created for the target protein. In case of long-term storage, the storage liquid is added and is stored at -80 °C. As a result of storage tests, it was confirmed that the quality could be maintained for six months in the above storage condition.

3.3 Establishment of PAA detection method

The assay by PAA can be completed in about eight hours from the initial probe (serum, low molecular compound, proteins, etc. that will be investigated for the bond with human protein) reaction to detection. The number of samples that can be processed per day is four samples per person. For detection, secondary antibodies labeled with fluorescent pigment or secondary antibodies labeled with HRP for fluorescence detection are used. For detection, devices that can obtain the western blotting image can be used, such as the chemiluminescence image detector or fluorescence image detector that are commercially available. A liquid delivery pump is used for the cleansing process of the probe and the

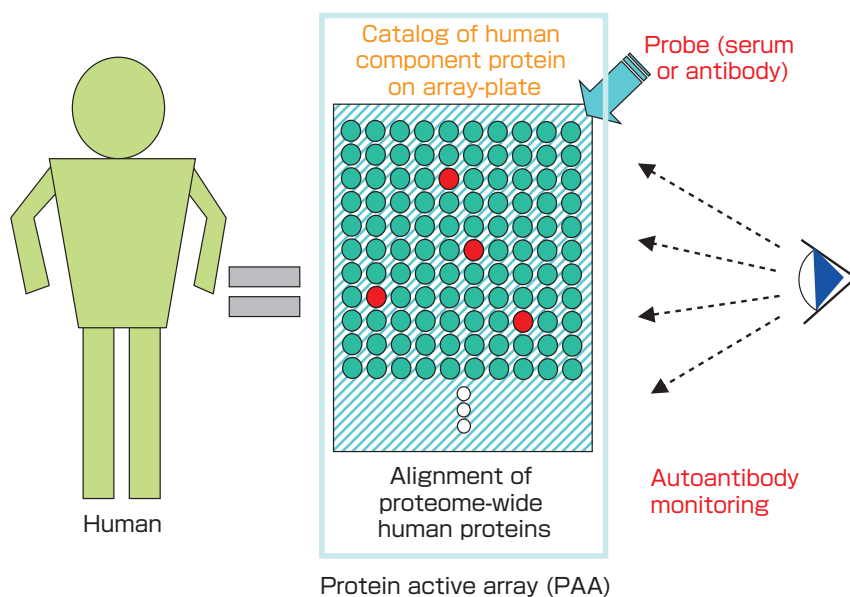

Fig. 4B Panoramic analysis by PAA

Proteome-wide proteins are arranged as arrays on a substrate, serum or antibodies that act as probes are added, bonding of antibodies to human proteins are investigated panoramically, and the autoantibodies are monitored.

reaction solution, and these can be automated in the future.

3.4 Establishment of the screening method for PAA

We are capable of synthesizing about 20,000 types of proteins in a short time by combining the protein synthesis technology and the dispenser. To screen proteins efficiently and economically using these characteristics, it is necessary to achieve higher density of PAAs or higher efficiency of screening. Cost and labor are needed to manufacture the protein arrays using the 20,000 proteins that were expressed individually and to identify the antigens, and problems may arise in the practical use and measurement of multiple samples. Therefore, we thought we could reduce the cost and labor to about one-tenth by conducting primary screening by creating an array using a compound of 10 types of proteins, and then conducting secondary screening using only the protein compounds containing the hits.

Several manufacture methods of the mixture of 10 proteins were considered. The method whereby simply synthesizing 10 proteins independently and then mixing the individual proteins would require cost and labor. Therefore, we investigated in which phase of the protein synthesis the 10 proteins could be combined for the co-expression of 10 types of proteins. In our protein synthesis system explained above (Fig. 3), the protein syntheses are conducted by mixing 10 types of entry clones, LR reaction products, PCR products, and mRNAs from each reaction step. The expressed proteins are separated by the SDS-PAGE method, and are detected by the western blotting method. In the western blotting method, anti-GST HRP-linked mouse mono Ab (NACALAI) is added to the antibody, diluted 5,000 times in 1.0 % skim milk in PBST, antibody reaction done for five minutes using ECL plus (GE Healthcare), and chemiluminescence detection is done using the Fluor-SMAX (Bio-Rad Laboratories, Inc.). As a result, for the co-expression of 10 proteins, 10 protein types were expressed efficiently in the mixture after the PCR product. Considering the cost and the complexity of the maneuver, it is concluded that the protein synthesis should be done after manufacturing the 10 mixtures using the PCR products from the uppermost stream (Fig. 5).

Using the PAA manufactured from the 10 types of co-expressed proteins synthesized from the mixed PCR product, we conducted an investigation of antigen-antibody reaction for the antibody to determine the antigen. As a result, the antigen could be identified using the PAA manufactured using the 10 types of co-expressed proteins.

The two-step screening method, where the 10 types of proteins obtained in the primary screening or comprehensive PAA (C-PAA) using 10 types of co-expressed protein are individually used to conduct antigen identification in the secondary screening expanded PAA (E-PAA), was employed. The screening is simplified using this two-step screening

method (Fig. 6).

Using this array technology, we manufactured PAAs for about 20,000 types of proteins that are categorized by function. The manufacturing technology of PAAs was transferred to Cell Free Sciences, Co. Ltd. that is working on the product realization of the PAAs.

3.5 Analysis of the autoantibody in the blood serum of a patient with ovarian carcinoma derived paraneoplastic cerebellar degeneration

Using the PAA, the analysis of the autoantibody in the serum of a paraneoplastic cerebellar degeneration (PCD) patient was conducted. The patient visited the Department of Neurology,

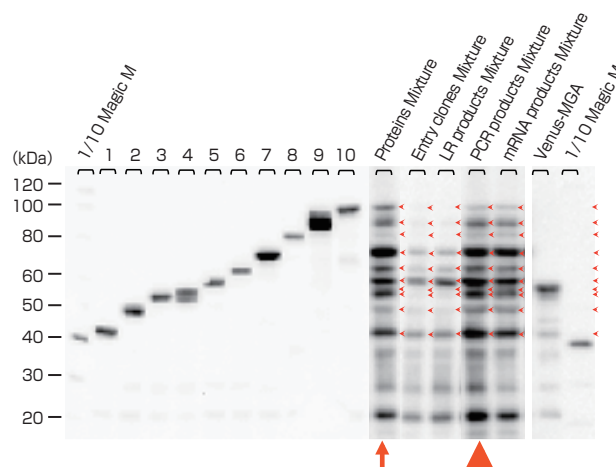

Sample no.	ID	SSG(STOP)	FLJ No	ORF Len (bp)	PCR product (bp)	MW(kDa)	Molecular weight of protein expressed by a native type entry clone
1	TEST0003	test clone No.56	FLJ21903	378	3105	14.7	44.4
2	TEST0001	test clone No.5	FLJ20819	624	3351	23.5	53.2
3	TEST0011	EGFP		720	3447	26.9	56.7
4	TEST0012	Venus-MGA		762	3489	28.2	58.0
5	TEST0009	Ubiquitin	FLJ34456	858	3585	33.3	63.0
6	TEST0007	kinase	FLJ34101	966	3693	37.0	66.7
7	TEST0008	phosphatase	FLJ34434	1176	3903	43.3	73.1
8	TEST0005	Transcription factor	FLJ16264	1374	4101	53.0	82.8
9	TEST0010	Autophosphorylation	FLJ37986	1638	4365	61.4	91.2
10	TEST0002	test clone No.8	FLJ20768	1842	4569	66.9	96.7

Fig. 5 Comparison of protein co-expression

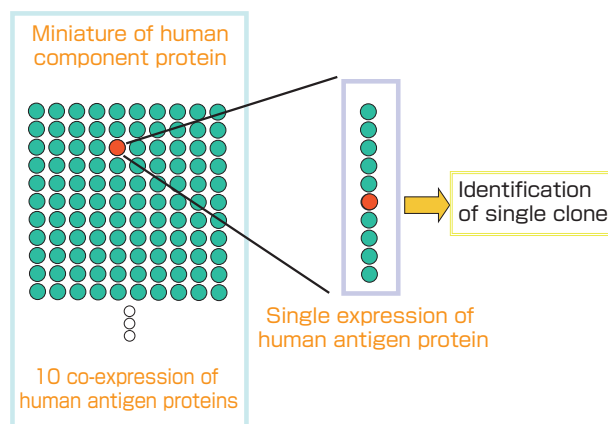

Protein active array (PAA)

Fig. 6 Antigen identification by C-PAA and E-PAA

The University of Tokyo Hospital, with numbness in the hands as an initial symptom. The patient's blood serum was diluted 1,000 times with PBS-T, and the autoantibody detection was conducted using the chemiluminescence detector using the HRP-labeled anti-human IgG antibody. From the detection results, about 37 types of autoantibodies were found (Fig. 7). The list of detected autoantibodies are shown as antigens in Table 2. LIMS1 and TRIM21 are autoantibodies that are detected highly frequently (80 % or higher) in healthy individuals. Although it has been reported that TRIM21 may be a marker antibody for lung cancer,^[9] in our research, it was detected at high percentage (65 % or higher) in healthy individuals. Recently, the relationships to cancer have been reported for the SSX family of SSX1, SSX2, SSX3, SSX4B, and SSX5,^[10] cancer antigens (CTA) CTA45A4 and CTA45A5, and lipase MGLL.^[11] The antigen proteins of the autoantibodies detected this time were also reported to be related to cancer. On the other hand, IRX2 is a factor related to the formation of cerebellum,^[12] and CTNNB2 is a protein related to the intercellular communication in the neurological connection.^[13] From these findings, it was shown that the autoantibodies in the serum could be comprehensively

detected using the PAA, and the antibodies related to cancer and cerebellar degeneration were detected. Since the cancer antibody was detected by the serum antibody analysis, the patient underwent thorough tests for cancer, and an ovarian tumor was found. It is not uncommon to find cancer in patients who visit the neurology department after experiencing some neurological symptoms. First, the cancer develops and several autoantibodies are produced as a result, and some of the autoantibodies may lead to neurological diseases. Currently, we are investigating whether these detected antibodies may become new biomarkers, by employing the JST Advanced Measuring and Equipment Development Program for 2012~2015 to obtain and analyze the autoantibody data of several patients and healthy subjects. If the autoantibody profiling can be done inexpensively and quickly using the PAA, it may be an extremely effective method for increasing the precision of various diagnoses.

4 Future issues

It is said that the antibodies are produced in large amounts, almost as much as the amplification of PCR against the

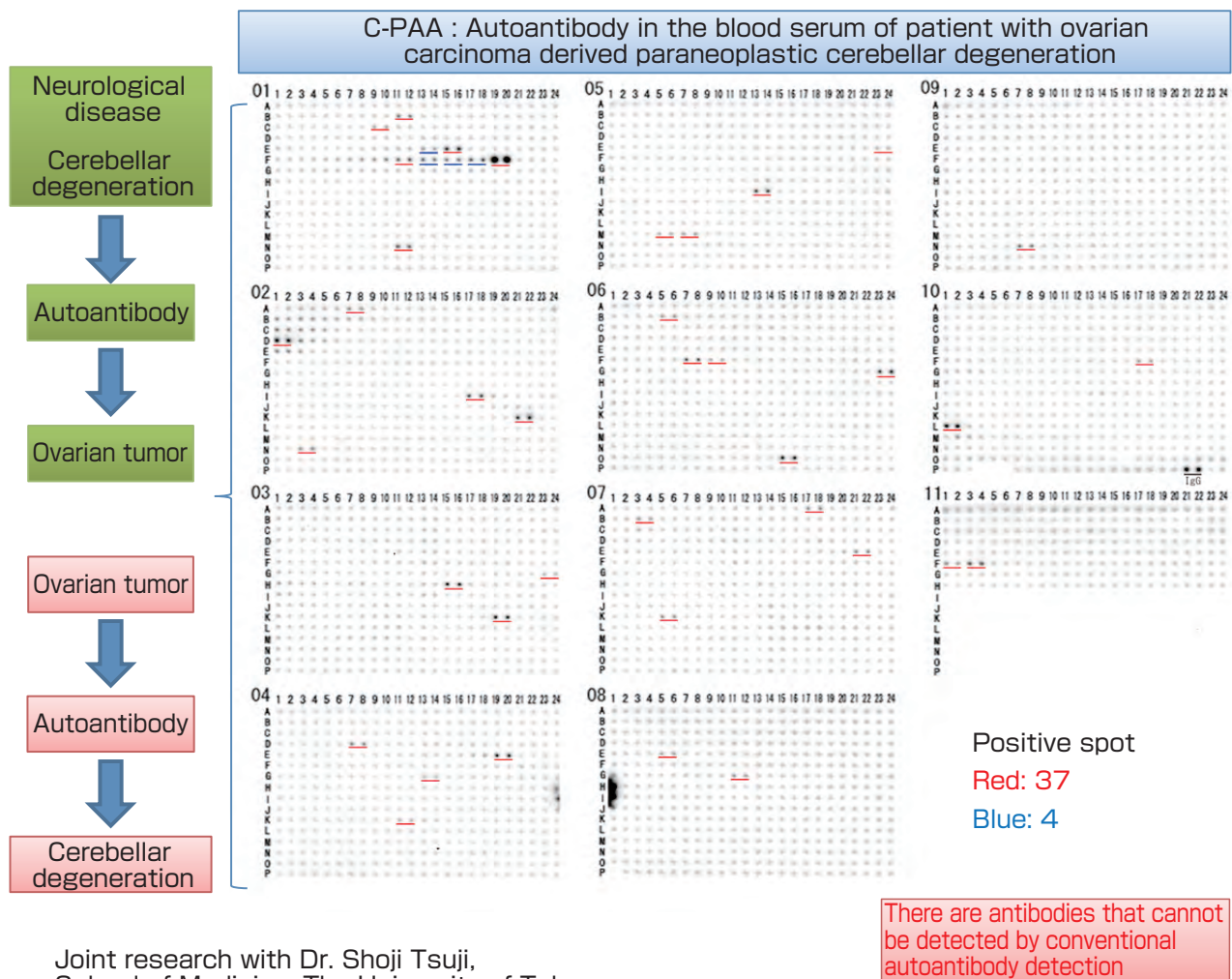

Joint research with Dr. Shoji Tsuji,
School of Medicine, The University of Tokyo

Fig. 7 Autoantibody detection from serum of patient with paraneoplastic neurological disease

Table 2. Autoantibody analysis of serum of patient with paraneoplastic neurological disease

Purified antibody no.	FLJ no.	GeneSymbol	Description
1	FLJ96281AAAF	DUSP11	dual specificity phosphatase 11 (RNA/RNP complex 1-interacting)
2	FLJ44773AAAF	A1BG	
3	FLJ81708AAAF	SSX2	synovial sarcoma, X breakpoint 2
4	FLJ81661AAAF	SSX1	synovial sarcoma, X breakpoint 1
5	FLJ82512AAAF	SSX3	synovial sarcoma, X breakpoint 3
6	FLJ81139AAAF	SSX5	synovial sarcoma, X breakpoint 5
7	FLJ13227AAAF	NXT2	nuclear transport factor 2-like export factor 2 (NXT2)
8	FLJ25823AAAF	CT45A4	cancer/testis antigen family 45, member A4
9	FLJ44051AAAF	LOC100128002	
10	FLJ13132AAAF	BAT5	
11	FLJ45293AAAF	GTNNA2	catenin (cadherin-associated protein), alpha 2
12	FLJ94954AAAF	LIMS1	LIM and senescent cell antigen-like domains 1
13	FLJ81000AAAF	SSX4B	synovial sarcoma, X breakpoint 4B
14	FLJ81065AAAF	TRIM21	tripartite motif-containing 21
15	FLJ96747AAAF	CD320	
16	FLJ96595AAAF	MGLL	
17	FLJ83136AAAF	CT45A5	cancer/testis antigen family 45, member A5
18	FLJ31021AAAF	LOC100129917	hypothetical protein LOC100129917
19	FLJ93657AAAF	RPL3L	ribosomal protein L3-like (RPL3L)
20	FLJ93363AAAF	MLL13	myeloid/lymphoid or mixed-lineage leukemia (trithorax homolog, Drosophila); translocated to, 3
21	FLJ92129AAAF	RPL6	60S ribosomal protein L6
22	FLJ92146AAAF	RGS16	regulator of G-protein signalling 16
23	FLJ96402AAAF	RGS5	regulator of G-protein signalling 5
24	FLJ96688AAAF	RGS1	regulator of G-protein signalling 1
25	FLJ30022AAAF	RGS3	regulator of G-protein signalling 3
26	FLJ20416AAAF	NXF2B	nuclear RNA export factor 2B
27	FLJ31197AAAF		
28	FLJ37690AAAF		
29	FLJ39521AAAF		
30	FLJ38906AAAF		
31	FLJ25862AAAF		
32	FLJ27182AAAF		
33	FLJ44385AAAF		
34	FLJ56587AAAF		
35	FLJ41898AAAF		
36	FLJ82376AAAF	IRX2	Iroquois homeobox 2

➡ Cancer related ➡ Cerebellum related

amount of antigens. The antibodies circulate throughout the body through blood, and therefore, it is thought that minute changes in the body can be found by studying the antibodies. In fact, it is becoming possible to profile the changes in autoantibodies of the body using PAAs, and the autoantibody detection system is entering the practical phase in terms of technology.

In the future, the comprehensive detection system for autoantibody using PAAs will allow the autoantibodies to be profiled comprehensively for various diseases such as cancer and autoimmune diseases, and we hope to accumulate the data on the relationships between several diseases and autoantibodies. By doing this, we hope it will become possible to conduct an integrated test through autoantibody profiling of the blood, to allow the evaluations of progress and treatment of disease, early detection, policy for diagnosis and treatment, and therapeutic effects. In the development of PAAs, we are working on achieving higher density of protein arrays, and on finding economic ways of conducting highly sensitive measurement using small quantities of blood. We also wish to create a system that can be used easily in general hospitals and research facilities.

References

[1] R. H. Scofield: Autoantibodies as predictors of disease, *Lancet*, 363 (9420), 1544-1546 (2004).
 [2] N. Goshima, Y. Kawamura, A. Fukumoto, A. Miura, R. Honma, R. Satoh, A. Wakamatsu, J. Yamamoto, K. Kimura, T. Nishikawa, T. Andoh, Y. Iida, K. Ishikawa, E.

Ito, N. Kagawa, C. Kaminaga, K. Kanehori, B. Kawakami, K. Kenmochi, R. Kimura, M. Kobayashi, T. Kuroita, H. Kuwayama, Y. Maruyama, K. Matsuo, K. Minami, M. Mitsubori, M. Mori, R. Morishita, A. Murase, A. Nishikawa, S. Nishikawa, T. Okamoto, N. Sakagami, Y. Sakamoto, Y. Sasaki, T. Seki, S. Sono, A. Sugiyama, T. Sumiya, T. Takayama, Y. Takayama, H. Takeda, T. Togashi, K. Yahata, H. Yamada, Y. Yanagisawa, Y. Endo, F. Imamoto, Y. Kisu, S. Tanaka, T. Isogai, J. Imai, S. Watanabe and N. Nomura: Human protein factory for converting the transcriptome into an in vitro-expressed proteome, *Nat. Methods*, 5 (12), 1011-1017 (2008).
 [3] Y. Maruyama, A. Wakamatsu, Y. Kawamura, K. Kimura, J. Yamamoto, T. Nishikawa, Y. Kisu, S. Sugano, N. Goshima, T. Isogai and N. Nomura: Human Gene and Protein Database (HGPD): a novel database presenting a large quantity of experiment-based results in human proteomics, *Nucl. Acids Res.*, 37 (suppl. 1), D762-D766 (2009).
 [4] M. Maekawa, K. Yamaguchi, T. Nakamura, R. Shibukawa, I. Kodanaka, T. Ichisaka, Y. Kawamura, H. Mochizuki, N. Goshima and S. Yamanaka: Direct reprogramming of somatic cells is promoted by maternal transcription factor Glis1, *Nature*, 474, 225-229 (2011).
 [5] J. L. Hartley, G. F. Temple and M. A. Brasch: DNA cloning using in vitro site-specific recombination, *Genome Res.*, 10, 1788-1795 (2000).
 [6] Y. Kawamura, N. Goshima and N. Nomura: Human protein factory: an infrastructure to convert the human transcriptome into the in vitro-expressed proteome of versatile utility, *Tanpakushitsu Kakusan Koso*, 54 (9), 1173-1181 (2009) (in Japanese).
 [7] K. Madin, T. Sawasaki, T. Ogasawara and Y. Endo: A highly efficient and robust cell-free protein synthesis system prepared from wheat embryos: Plants apparently contain a suicide system directed at ribosomes, *Proc. Natl. Acad. Sci. USA*, 97 (2), 559-564 (2000).

- [8] Y. Maruyama, Y. Kawamura, T. Nishikawa, T. Isogai, N. Nomura and N. Goshima: HGPS: Human Gene and Protein Database, 2012 update, *Nucl. Acids Res.*, 40 (D1), D924-D929 (2012).
- [9] M. Kuboshima, H. Shimada, TL. Liu, F. Nomura, M. Takiguchi, T. Hiwasa and T. Ochiai: Presence of serum tripartite motif-containing 21 antibodies in patients with esophageal squamous cell carcinoma, *Cancer Sci.*, 97 (5), 380-386 (2006).
- [10] B. J. Taylor, T. Reiman, J. A. Pittman, J. J. Keats, D. R. de Bruijn, M. J. Mant, A. R. Belch and L. M. Pilarski: SSX cancer testis antigens are expressed in most multiple myeloma patients: co-expression of SSX1, 2, 4, and 5 correlates with adverse prognosis and high frequencies of SSX-positive PCs, *J Immunother.*, 28 (6), 564-575 (2005).
- [11] E. Leah: Lipidomics: Growing on a free-fat diet, *Nat. Rev. Cancer*, 10, 160 (2010).
- [12] K. Matsumoto, S. Nishihara, M. Kamimura, T. Shiraishi, T. Otoguro, M. Uehara, Y. Maeda, K. Ogura, A. Lumsden and T. Ogura: The prepattern transcription factor *Irx2*, a target of FGF8/MAP kinase cascade, is involved in cerebellum formation, *Nat. Neurosci.*, 7 (6), 605-612 (2004).
- [13] M. Zhang, J. Zhang, SC. Lin and A. Meng: β -Catenin 1 and β -catenin 2 play similar and distinct roles in left-right asymmetric development of zebrafish embryos, *Development*, 139 (11), 2009-2019 (2012).

Authors

Yoshitaka KAWAKAMI

Withdrew from the doctorate course after obtaining the necessary credits from the Graduate School of Science, Osaka City University in 2008. Participated in the Regional Innovation Creation R&D Program “Development of Efficient Tumor Serum Marker by Random Immunization” and “Development of Comprehensive Diagnostic System for Specific Cancers Using Autoantibodies,” as a technical staff at the Biomedical Information Research Center, AIST. Also worked in the “Multi-Institutional Pre-Phase II Clinical Trial for Post-Operative Esophageal Cancer Cases for CHP/NY-ESO-1 Polypeptide Cancer Vaccine” of the Ministry of Health, Labour and Welfare. Joined the Fukushima Medical Industrial Translational Research Project as a researcher of the Japan Biological Informatics Consortium from May 2013 to present. In this paper, was in charge of the creation of protein array and autoantibody measurement.



Naoki GOSHIMA

Completed the courses at the Department of Biochemistry, Graduate School of Agriculture and Biological Sciences, Osaka Prefecture University in 1987 (Doctor of Agricultural Science). Flexible Researcher, RIKEN; Assistant, Kyoto Pharmaceutical University; Assistant Professor, Graduate School of Science, Hiroshima University; and currently, Team Leader, Quantitative Proteomics Team, Molecular Profiling



Research Center for Drug Discovery, AIST. Participated in the “Protein Function Analysis Project” of the New Energy and Industrial Technology Development Organization (NEDO) from 2000, and engaged in genome-wide protein functional analysis based on the Gateway creation of human full-length cDNA and comprehensive protein expression. Utilized the human protein expression resource and obtained results for the NEDO “Chemo-Bio Project,” NEDO “TR Product,” and “Special Project for Yamanaka iPS Cell” of Japan Science and Technology Agency in 2006. Engaged in the development of PAA in the Kyushu Regional Consortium in 2006 and the Kanto Regional Innovation in 2008~2010. Conducted the autoantibody profiling in blood sample to search for autoantibody biomarker. In this paper, was in charge of supervising the protein array research and collaboration with the medical practices.

Discussions with Reviewers

1 Overall comments

Question and comment (Yasushi Mitsuishi, AIST Tohoku)

I read this paper with interest, on the use of the results of the national project following from the human full-length cDNA project, and on the possibility of enabling early diagnosis of disease through blood serum autoantibody profiling that was not initially considered. I understood the idea that some kind of autoantibody is produced excessively in the development of a disease and that this can be used as a disease marker, but I felt the explanation of the technological result was too brief and I was somehow left unsatisfied. The paper seems to finish with the conclusion that you created a PAA that allows the comprehensive analysis of the bonded protein in blood serum. While it is great that you can do comprehensive analysis of proteins, but in this paper, please describe in detail the types of serum autoantibodies, the amount, and the level at which the presence and degree of disease can be estimated.

Answer (Naoki Goshima)

The detailed results described in the initial manuscript will be submitted to a specialized journal, including the consideration of autoantibody as a marker. Therefore, I responded to your comment by including the analysis of the autoantibodies in the blood serum of a patient with ovarian carcinoma derived paraneoplastic cerebellar degeneration as the data of the paper that focuses on the development of protein array technology.

2 Concept of PAA

Question and comment (Noboru Yumoto, AIST)

The objective of this research is “the development of a comprehensive detection system for autoantibodies,” and centering on the major breakthrough of “the construction of the world’s largest protein expression resource,” the scenario, in which the elemental technologies including comprehensive protein expression technology, protein array technology, antibody detection technology, and screening technology were integrated, is understandable to the readers of the bio field. However, I think it is difficult for people outside the field to understand what actually is a proteome array. Therefore, can you include a conceptual diagram of the PAA that you developed?

Answer (Naoki Goshima)

I added the conceptual diagram of the PAA to Fig. 4B, and added explanations to the diagram, Fig. 4.

Technological development of internal heat-integrated distillation column (HIDiC)

— Substantive research of application to a bench plant of bioethanol distillation —

Kunio KATAOKA* and Hideo NODA

[Translation from *Synthesiology*, Vol.7, No.3, p.163-178 (2014)]

To dramatically reduce energy consumption in chemical industry, we propose to construct a database on fundamental technologies for practical applications of HIDiC, as part of a project funded by NEDO (New Energy and Industrial Technology Development Organization). An application of HIDiC to the distillation process for the enrichment of bioethanol fermented from biomass has been attempted, and a bench plant has been designed and constructed to ensure practical applicability. Testing has shown that the developed HIDiC system achieves the project targets of enrichment and energy savings. We also confirmed that a compressor-free HIDiC system can be scaled to commercial plants.

Keywords : HIDiC distillation column, bioethanol distillation, internal heat integration, energy saving, lift tray, bench plant

1 Introduction

Distillation process serving as the leading part of separation technologies occupies approximately 40 % of the total energy consumed by chemical industry in Japan. Many years have passed since the national program of energy conservation started. Our fundamental research on the energy saving distillation technology by internal heat integration (called “The first-term project”) was conducted as a project of the New Sunshine Program. After the first-term project, our next-phase project entitled “Development of energy-saving distillation technology by internal heat integration” (called “The second-term project”)^{[1][2]} was conducted for four years from 2002 as part of the new technology NEDO program for prevention against global warming, NEDO being the New-Energy and Industrial Technology Development Organization. The objective of the second-term project was to contribute to the development of energy-saving technology for reducing the consumption of fossil resources. The project team^[1] consisted of the National Institute of Advanced Industrial Science and Technology (AIST) serving as the project leader, Maruzen Petrochemical Co., Ltd., Kimura Chemical Plants Co., Ltd., Kansai Chemical Engineering Co., Ltd., Taiyo Nippon Sanso Corporation, and Kobe Steel, Ltd. The target of our project authorized by NEDO was specified to be 30 % or more reduction of the energy consumed by an ordinary distillation column.

The petrochemical industry group in this team successfully constructed a pilot plant of HIDiC packed column in February, 2005. The first column (bubble-cap trayed column)

of C5-splitter existing in the Chiba factory of Maruzen Petrochemical was selected as the subject of the project objective. A continuous 1000 hour test run was successfully achieved with higher than 60 % of energy saving rate.^{[1]-[3]}

As the existing C5-splitter was treating a clean service producing pure cyclopentane from a mixed gasoline, a packed-column type HIDiC pilot plant was manufactured by Kimura Chemical Plants. The reasons why a packed column structure was selected were because

- (1) substantial data were available of the basic research of HIDiC process and system accumulated by Kyoto University and AIST,
- (2) large energy-saving rate can be expected if internal reflux liquid is distributed evenly over the heat transfer surfaces of packed columns,
- (3) no problem of fouling and plugging/blockade owing to the clean service of petrochemicals.

Thereafter a collaborative study of HIDiC consortium was conducted by AIST serving as the leader for the purpose of practical propagation of HIDiC technology. However although the very high energy-saving effect of HIDiC technology was recognized, no commercial-scale HIDiC system was realized. One of the reasons was that most of petrochemical companies had more than enough volume of steam from the direct cracking process which releases high temperature cascade heat. A more important problem was that a big compressor with a large discharge rate was required in the HIDiC system. In addition, an original HIDiC system was not suitable for dirty service of distillation. For example,

Kansai Chemical Engineering Co. Ltd., 2-9-7 Minami-nanamatsu-cho, Amagaki 660-0053, Japan

* E-mail: kataoka@kce.co.jp

Original manuscript received February 25, 2010, Revisions received December 24, 2010, Accepted December 24, 2010

it was difficult to treat biomass product mixtures such as bioethanol and biodiesel solutions including lignins, glucans, ashes, and enzyme proteins as fermentation residues. Consequently Kansai Chemical Engineering devised a new HIDiC system which does not need a compressor (called “compressor-free HIDiC” and CF-HIDiC for short). In order to develop this patented system,^[4] our own project (called “The third-term project”)^[5] was conducted by ourselves for three years from 2007. As a result, it was confirmed that the compressor-free HIDiC system could give more than 30 % reduction of energy consumption.

On the other hand, another NEDO project for the development of biomass energy such as biofuel ethanol came up focusing on the energy saving of enriching processes as well as cost reduction of enzyme and yeast. We joined that NEDO project to boost bioethanol distillation. The project was entitled “Development of environment-friendly overall processes for high-efficiency production of bioethanol” (2008 ~ 2012).^[6] In this project (called “The fourth-term project”), we were assigned to apply our new HIDiC technology to the dirty-service distillation for enriching bioethanol from the fermented mash. We succeeded at long last in constructing a HIDiC bench plant in 2012. It was confirmed by our test operation that the project target of energy consumption allocated to the enriching process was successfully achieved, and thus the possibility of practical application of our developed HIDiC system was shown. In the following part of this paper, we would like to discuss from various viewpoints of *Synthesiology* how this HIDiC technology was developed as well as how our sequential projects were conducted.^[7]

2 How to execute a project for technological development

Details of development of the technology are explained in chapters 3 and 4. From the viewpoint of *Synthesiology*, in this chapter, the following issues will be analyzed and discussed to extract a methodology of technological development from our experience: (1) how to execute various phases of projects for the technological development, and (2) how to attain a breakthrough to overcome various difficult problems.

2.1 How to grasp technological issues and how to make project purposes definite

The main subject of the NEDO second project (No. P02020: Technological development of internal heat-integrated distillation column for energy conservation) was derived from the Kyoto Protocol for the prevention of global warming. That was a very important national policy of energy and environment recognizing that a big effect of energy saving in distillation processes of chemical industry would lead to the reduction of the import volume of crude oil and the reduction of greenhouse gas emissions. Regarding the energy-saving technologies in chemical industry of the day, after the oil crises, various process improvements for

eliminating waste of energy and materials were already performed in the chemical industry. Further reduction of energy consumption was assumed almost impossible unless drastic measures of technological innovation were realized.

Historically speaking, an idea of introducing a heat pump into a distillation system was first proposed by Mah *et al.*(1977).^[8] Unfortunately nobody had thereafter paid earnest attention to it. No distillation engineering researchers could have a concrete image of its practical internal structure because their paper discussed its possibility by system analysis only from a viewpoint of process system engineering. A big fireproof compressor required for pressurizing the rectifying section was regarded inadequate for distillation processes. Then the late Prof. Takamatsu of Kyoto University recognized that a national project of technological development for introducing the principle of heat pump into distillation would be noteworthy for the drastic reduction of energy consumption in chemical industry.

The standard system of internal heat-integrated distillation column (called HIDiC for short)^[8] proposed at the beginning of the first-term project is shown in a form of double-tube type structure in Fig. 1. The vapor issuing from the top of the stripping section is pressurized by a compressor and supplied into the bottom of the rectifying section. Therefore the temperature of the rectifying section can be made higher than that of the stripping section. If the high-temperature rectifying section comes into thermal contact with the low-temperature stripping section, partial condensation of upward-rising vapor occurs in the rectifying section while partial vaporization of downward-falling liquid occurs in the stripping section owing to the internal heat transfer from the rectifying to the stripping section. The partial vaporization due to this internal heat exchange can greatly reduce the heat duty of the bottom reboiler. The partial condensation in the rectifying section can also reduce the cooling duty of the overhead condenser.

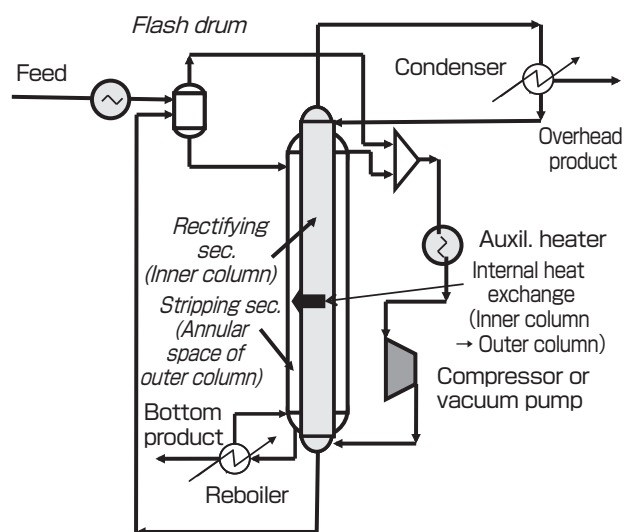

Fig. 1 Standard HIDiC system (Double-tube type)

2.2 Cooperation of heat transfer engineering with process system engineering

The first-term project was started by process system engineers and researchers who noticed the significance of the idea of Dr. Mah *et al.*^[8] Their project team was organized in concert with a petrochemical company and plant engineering companies. The education and research on distillation of the day were done based on the thermodynamics of vapor-liquid equilibrium and the process system engineering using an ideal plate model.

However we know that the distillation process essentially proceeds due to simultaneous heat and mass transfer. One of the authors thereafter joined the second-term project as a researcher of heat transfer engineering. We discussed and amended together the objective of the second-term project in order to construct a database of internal heat integration characteristics based on the concept of heat transfer engineering. The internal heat transfer due to the temperature difference between the rectifying and stripping sections can be analyzed with an overall heat transfer coefficient U and an effective heat transfer area A .

An important issue was to observe a control parameter set of U and A as the characteristics of internal heat transfer by an experimental apparatus of practical-scale HIDiC column. A database of UA made it possible to perform a process simulation analysis of the commercial-scale HIDiC plant design for various distillation processes. As mentioned above, the second-term project succeeded in the construction of a packed column-type HIDiC pilot plant as an alternative of the first column of the existing C5-splitter taking into account the process simulation analysis.^{[2][3]}

2.3 Devising a new HIDiC system for propagation – The third-term project –

By using mixed gasoline including cyclopentane as a key component, the second-term project succeeded in a continuous 1000 hour test run of the pilot plant with a very high rate (more than 60 %) of energy saving, which was constructed as an alternative of the C5-splitter first column. However commercial-scale application following this pilot plant was not realized. This was due to the fact that the success was achieved by the standard HIDiC system equipped with a large compressor for a clean service distillation of petrochemical hydrocarbons. Usually there are various dirty mixtures and inflammable mixtures to be separated by distillation. After considering various issues, we devised a compressor-free HIDiC (called “CF-HIDiC” for short). Figure 2 shows a compressor-free HIDiC flow system.^{[4][5]}

The third-term project proposed by Kansai Chemical Engineering was approved by NEDO expecting a useful outcome of this new HIDiC system. The CF-HIDiC system consists of two columns at least, where the first one is an ordinary column and the second one is a double-tube HIDiC

column. The first column can supply its high-pressure overhead vapor into the bottom of the HIDiC rectifying section without a compressor. The creative part is that the first column does not have an overhead condenser but the stripping section of the HIDiC column has an overhead condenser, and of which the condensate is fed back to the top of the first column. Although there is vaporization of the internal reflux liquid in the HIDiC stripping section due to the internal heat exchange, we provided an overhead condenser for condensing the overhead vapor of the HIDiC stripping section. That was regarded as a negative idea against the basic concept of HIDiC even in the project meeting. However the overhead condenser of the HIDiC stripping section can be regarded as an alternative of the first column condenser. In addition, its reflux liquid pump has negligible small power consumption in comparison to that of vapor compressors.

It is natural that the energy-saving effect of the CF-HIDiC is lower than that of the standard HIDiC because the first column is an ordinary column with no HIDiC energy-saving effect. However, with the advantage that no compressor is required, the CF-HIDiC has a possibility of more than 30 % reduction of energy consumed by an ordinary two-column system. The third-term project was started as a fundamental study by Kansai Chemical Engineering with the expectation that this CF-HIDiC system could be scaled to a commercial-scale big plant. In spite of the wild idea of the HIDiC stripping section equipped with an usual overhead condenser, the CF-HIDiC system was patented with no objections.^[4] Owing to the fact that no compressor was required, this system had good evaluation as a new HIDiC system with expectations for a considerably high energy-saving effect.

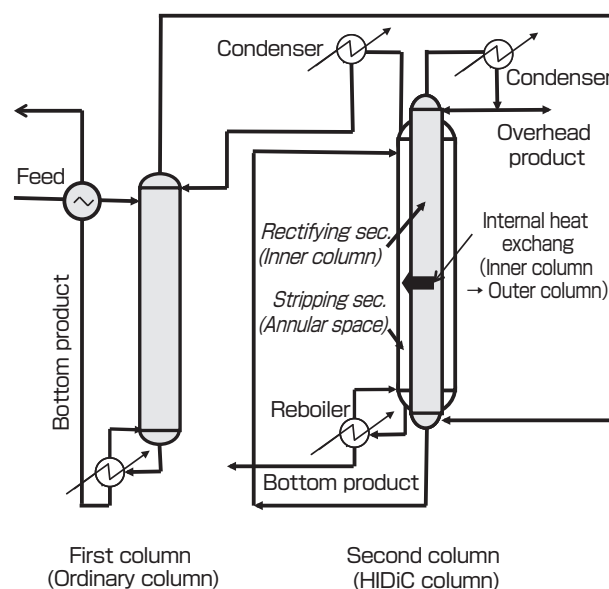

Fig. 2 Compressor-free HIDiC system (called CF-HIDiC for short)^{[4][5]}

2.4 Search for a road contributive to practical use – The fourth-term project –

Taking into account that various enlightening movements for practical propagation of the CF-HIDiC did not gain good results, we amended our aim to boost different applications involved in other projects. We joined a NEDO project (No. P07015) entitled “Development of environmentally benign and consolidated process for efficient production of cellulosic ethanol.” The purpose of the project was technological process development for high-efficient production of bioethanol from soft biomass. As the authorized target of the project, the total cost of production of 1 litre of dehydrated ethanol was set at JPY 40/L-EtOH (USD 0.4/L-EtOH). The main objectives of the project were (1) how to reduce the cost of the enzyme and yeast consumption, (2) how to make use of the arming technology displaying both cellulase and hemicellulase on the surface of yeast cells for simultaneous saccharification fermentation. However the ordinary distillation technology selected as the first candidate for enriching the fermented mash did not permit a drastic reduction of energy requirement. In order to realize a big reduction in the total cost of production, it was of great importance to innovate HIDiC technology within the total process of producing ethanol highly efficiently from biomass. Taking into account that the process producing ethanol from biomass can be regarded as a carbon-neutral process, we decided to join the project in order to make a contribution to a dramatic reduction of energy consumption required for the bioethanol process.

2.5 Challenge to application for a new process – A troublesome problem should be regarded as a true need for innovation –

The fermented mash produced from soft cellulosic biomass contains various fermentation residues, saccharides, lignins, enzymes, and inorganic salts, some of which remain as non-volatile substances in the liquid mixture even after filtration. It was feared that these non-volatile substances might obstruct heat transfer fouling the heat transfer surfaces of the HIDiC column and the reboiler. We faced a very important problem as to how to try fouling tests before making the structure of HIDiC bench plant concrete. We hit upon a good idea making use of our original jacketed tank evaporator (named “Wall Wetter Evaporator”) as a simulated double-tube type HIDiC column. As will be mentioned later in Fig. 9, the inner surface of the evaporator kettle can be regarded as the heat transfer surface of the HIDiC stripping section whereas the outer jacket-side surface serves as the heat transfer surface of the HIDiC rectifying section. The fouling test using mash liquid fermented from rice straw successfully investigated the effect of the boiling point by varying the operating pressure of the evaporator kettle.

2.6 Conflict between goals of energy conservation and fermentation – Reconsideration of respective goals –

The bioprocess team was also facing difficulty in raising the ethanol yield of fermented mash. Large amount of energy would be assigned to the enriching process team for vaporization of a lot of water. Therefore, the ethanol concentration of fermented mash directly influences the energy-saving rate in the distillation process by HIDiC.

We, the enriching distillation team discussed with the bioprocess team of saccharification and fermentation on how high they could raise the ethanol yield by the fermentation process. The result of ethanol yield that the bioprocess team had reached at that time by the consolidated bio-processing process (abbreviated “CBP” process) amounted to 2 wt% of ethanol at the highest. For the case of the clean ethanol-water system, we analyzed by process simulation as to what concentration level of fermented mash ethanol was necessary in order for the standard HIDiC to attain the project target of energy savings. The result of the simulation analysis is shown in Fig. 3. Using Fig. 3, we insisted that, in order for the distillation team to attain the energy-saving target (allocated 4 MJ/L-EtOH for the standard HIDiC), the fermentation target of the bioprocess team should be raised up to 5 wt% of ethanol taking into account the fouling effect of the actual mash. The simulation analysis making use of the HIDiC database constructed in the third-term project was helpful for the reconsideration of the project targets.

2.7 Bench plant design specifications and test run results of the actual bench plant

At that time, HIDiC design manual had not been constructed because the internal structure of the HIDiC system was not yet definite. Fortunately we already owned an experimental apparatus of a commercial-scale double-tube trayed HIDiC column (The outer column: 800 mm ID and the inner column: 508 mm ID) and a big database of internal heat integration characteristics. These data were very useful for the process simulation analysis determining the design specification of the bench plant. As it was difficult to experimentally observe

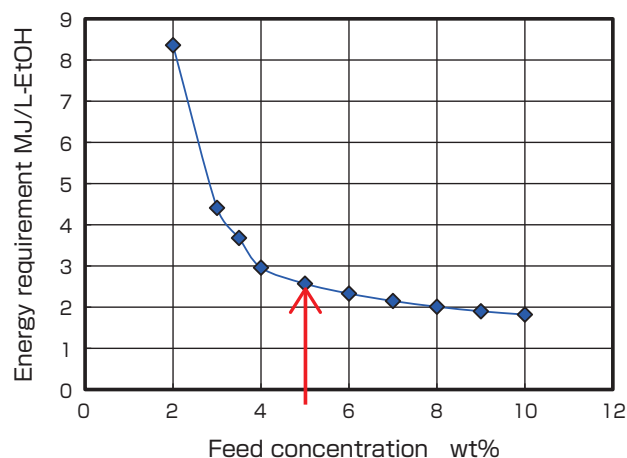

Fig. 3 Variation of energy requirement for standard HIDiC system with mash liquid ethanol concentration^[6]

the actual area of the internal heat exchange, for engineering purposes, the effective heat transfer area was estimated as the cylindrical surface area of the inner column determined from unit tray-to-tray spacing of actual trays. Therefore the overall heat transfer coefficient was underestimated as $U = 250 \text{ kcal/m}^2\text{h}^\circ\text{C}$, i.e. $290.75 \text{ W/m}^2\text{K}$. For bench plant design specification, the feed rate of the fermented mash liquid after filtration was set at 50 kg/h and its concentration was 5 wt% EtOH. The simulation analysis using this condition made the system design very easy. The result of simulation analysis will be given in Fig. 10.

Owing to the height limit (10 m or less) of the building, we were anxious about the deficiency in the number of trays for the first column (mash column) of CF-HIDiC equipped with 16 Change Trays. As will be shown in Fig. 16, the project target for energy requirement (5 MJ/L-EtOH) was actually just attained for the case of CF-HIDiC system.

2.8 Test operation of bench plant – Procedure and result –

Regarding how to start up, we experimentally tried various ways and discussed the procedures carefully.

As a result, the start-up procedure is given as follows.

(A) Standard HIDiC (see Fig. 12)

- (1) Exhaust air from the stripping section through the overhead condenser of the rectifying section by a dry vacuum pump, (2) supply live steam into the bottom of the stripping section, (3) then make both the rectifying and stripping sections full of steam only, (4) then start the supply of mash liquid as the feed (5) lower the pressure of the stripping section for the specified compression ratio under the total reflux condition, (6) adjust the column top temperature of the rectifying section near to azeotropic point reducing the live steam supply into the stripping section, and finally reduce the reflux ratio as much as possible in order to reach a steady state for obtaining the specified overhead product. At the optimum energy-saving condition, the live steam supply can be made exactly zero.

(B) CF-HIDiC (see Fig. 14)

- (1) Supply live steam into the bottom of the first column (mash column) in order to exhaust air or non-condensable gas of the first column and the HIDiC rectifying section from its overhead condenser, (2) then operate the two overhead condensers, (3) lower the HIDiC stripping section pressure by a water-sealed vacuum pump in order to bring the HIDiC column to an internal heat exchange condition, (4) transport the bottom liquid (water) condensed in the HIDiC rectifying section to the top of the HIDiC stripping section by the pressure difference, (5) supply live steam into the HIDiC stripping section bottom, (6) feed-back the condensate as a reflux from the HIDiC stripping section overhead condenser to the top of the first column, (7) discharge the internal reflux liquid

(water) from both the bottoms of the HIDiC stripping section and the first column, (8) then supply a mash liquid solution as the feed into the feed plate of the first column, (9) reduce the live steam supply into the HIDiC stripping section as much as possible, and (10) adjust the pressure ratio between the HIDiC rectifying and stripping sections reducing the live steam supply into the first column bottom so as to even out the top temperature of the HIDiC rectifying section down near to the azeotropic point. Comparing the start-up operation between the standard HIDiC and CF-HIDiC, the latter has been found to be much easier.

2.9 Key to achievement of the project target of energy saving

As a result of preliminary investigation, the purpose of the distillation team became how to reduce the live steam supply in place of the reboiler heat duty. As was anticipated, the live steam supply into the HIDiC stripping section could be saved much owing to the great effect of internal heat integration. Actually it became zero not only for the standard HIDiC system but also for the CF-HIDiC system. Regarding the standard HIDiC, we assured that the whole distillation system could be operated by electric power consumption only required for the dry vacuum pump. On the other hand, the energy-saving effect of the CF-HIDiC depended on how to reduce the live steam supply into the first column bottom in place of the bottom reboiler heat duty. The water-sealed vacuum pump installed beneath the overhead condenser of the HIDiC stripping section usually requires a negligibly small (of the order 1/100) electric energy consumption. In addition, the live steam supply into the HIDiC stripping section could be made zero at the optimum condition. However when the live steam supply into the first column bottom was largely saved, the ethanol concentration of the bottom product of the mash column rose beyond the effluent control (< 0.1 wt%). Regarding the CF-HIDiC, when the live steam supply was made 10.55 kg/h, we achieved at the lowest the energy-saving target (5 MJ/L-EtOH) satisfying the enriching target (more than 90 wt% EtOH) of the overhead product as well as the effluent control. It was also confirmed that the problem could be relieved if sufficient number of trays of the first column is permitted without the height limitation.

3 Technological development and database construction for commercial plant design in the second-term project

In the second-term project,^{[1][2]} our company was responsible for technological development of trayed HIDiC structures. We executed the project for construction of the design database of the internal heat exchange characteristics taking into consideration the realization of commercial plants in the next phase (The third-term project). The experimental

apparatus is shown in Fig. 4.

This experimental double-tube trayed HIDiC column was manufactured taking into account a possible plan of a HIDiC pilot plant in place of the existing first column of the aforementioned C5-splitter. The column diameters were determined based on F-factor necessary for the actual feed rate (approximately 1.6 ton/h). The inner column served as the pressurized rectifying section while the annular space of the outer column served as the stripping section. The inside diameter of the inner column was 508 mm and the inside diameter of the outer column was 800 mm. Both the columns were equipped with our original dual-flow trays called Lift Trays.

The Lift Tray, as shown in Fig. 5, is a set of two perforated plates, the upper floating one moving up and down depending on the vapor flow rate and the lower one being fixed. Therefore the Lift Trays can control the pressure drop automatically: when the vapor flow is increased, the upper perforated plate is lifted to increase the opening area. The self-controlling tray can be regarded suitable for HIDiC systems, because of the wide range of stable F-factor values

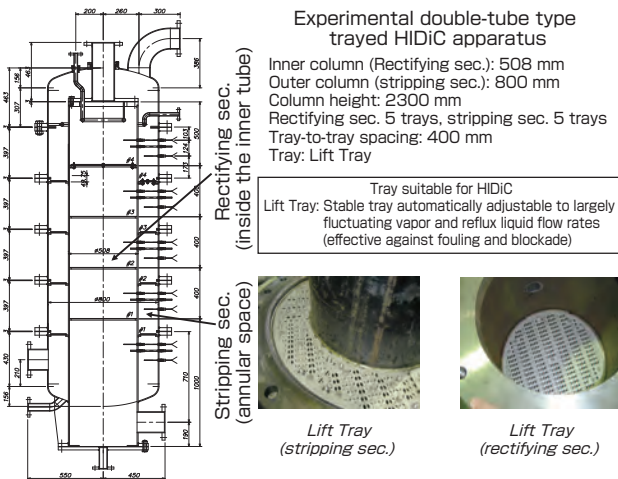

Fig. 4 Experimental apparatus of double-tube type HIDiC trayed column^{[2][5][19]}

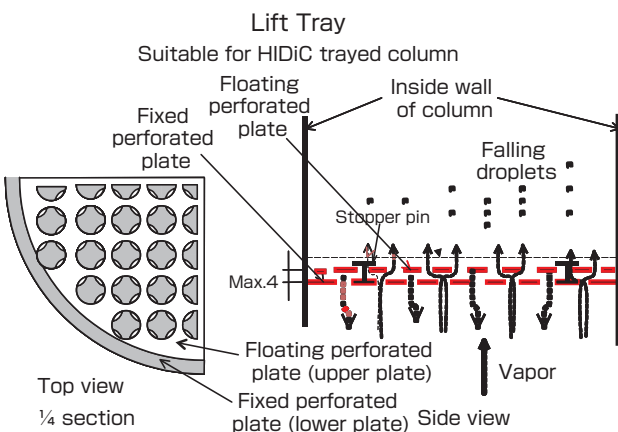

Fig. 5 Structure of Lift Tray

prior to flooding.

(Conception of heat transfer due to internal heat exchange)

Figure 6 shows a schematic picture of internal heat transfer occurring in a double-tube trayed HIDiC column. The partial condensation of vapor occurring in the pressurized rectifying section gives its latent heat by internal heat transfer to the stripping section for partial vaporization of the internal reflux liquid.

The overall heat transfer coefficient in the internal heat exchange can be defined as

$$U = \frac{Q_i}{A_i \Delta T_i}$$

The rate of heat transfer at individual trays is controlled by the partial condensation and partial vaporization. However owing to complicatedly fluctuating bubbling foams on trays, it was very difficult to strictly evaluate the effective area of heat transfer surface for the partial condensation and vaporization. From an engineering viewpoint for practical application, the heat transfer area A_i was defined as the surface area of the cylindrical wall of the inner column partitioned by actual tray-to-tray spacing. The temperature difference between the rectifying and stripping sections was taken as $\Delta T_i = Tr_i - Ts_i$. Therefore we obtained experimental data under the condition close to the bubbling foam height formed on actual tray spacing of practical apparatuses. The ratio of pressure between the rectifying and stripping sections, i.e. the compression ratio P_{air}/P_{ais} was used as the control parameter.

In the early period of the second-term project, we performed distillation experiment for the practically useful database of internal heat integration characteristics using a benzene-

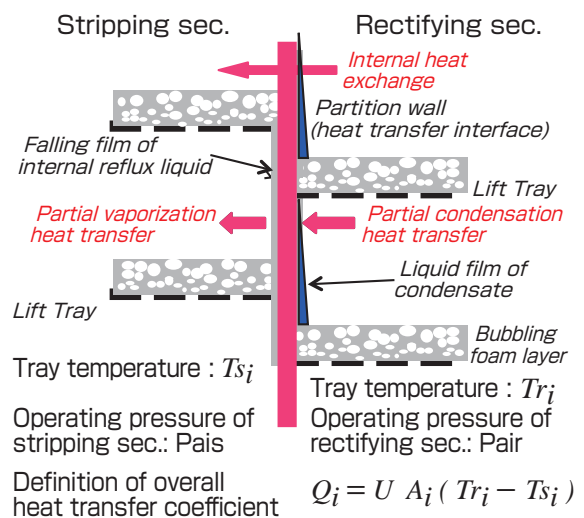

Fig. 6 Schematic picture of internal heat exchange occurring inside a HIDiC trayed column^[2]

toluene binary system as an ideal system of petrochemical hydrocarbon mixture, but in the later period, we devoted ourselves to an investigation of an ethanol-water system as a non-ideal system for a forthcoming challenging application to a bio-energy production process.^{[5][9][10]}

As will be mentioned later, overlooking the experimental error and the scattering data of overall heat transfer coefficient, it may be considered that the database should have a wide applicability by slight revision taking into account the effect of physical properties: the benzene-toluene data can be utilized for various hydrocarbons of usual molecular weight and the ethanol-water data could be utilized for various solution of water-soluble organic compounds such as methanol, propanol, acetaldehyde and MEK.

Our experiment was conducted by two operation modes: (1) pressurizing mode raising the rectifying section to higher than 1 atm ($P_{air} > 1 \text{ atm}$ and $P_{ais} = 1 \text{ atm}$) and (2) depressurizing mode lowering the stripping section to lower than 1 atm ($P_{air} = 1 \text{ atm}$ and $P_{ais} < 1 \text{ atm}$). The databases constructed with the control parameter of the compression ratio P_{air}/P_{ais} are available both for the standard HIDiC and CF-HIDiC systems.

As an example, some of the data of internal heat exchange for the ethanol-water system are shown in Figs. 7 and 8.^[5] Since boiling point rises with pressure, the characteristic temperature difference between the rectifying and stripping sections increases almost in proportion to the compression ratio. The correlation line of the pressurizing mode was different in slope from that of the depressurizing mode. The variation of the overall heat transfer coefficient was different between the pressurizing and depressurizing modes. It was confirmed that as the overall heat transfer coefficient for practical design, the underestimated value of $U = 500 \text{ kcal/m}^2\text{hr}\cdot\text{C} = 581.5 \text{ W/m}^2\text{K}$ should be recommended as a plant design on the safe side even for a clean ethanol-water system.

In the successive two projects (The second-term and third-term projects), the design database was constructed collecting

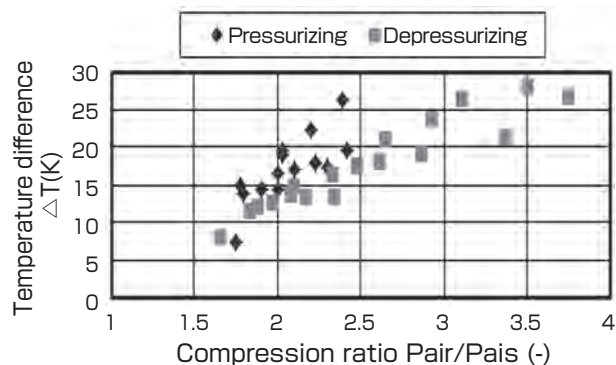

Fig. 7 Variation in temperature difference with compression ratio^[5]

many experimental data of distillation accompanied with internal heat exchange.^[5]

4 Enriching process of bioethanol – Research and development in the fourth-term project –

The HIDiC technology we developed did not spread among the petrochemical industry in spite of the assured great effect of energy saving. As our fourth-term project for breaking through the disadvantaged circumstances, we decided to join another NEDO project in order to boost the development of a new carbon neutral bioprocess producing biofuel ethanol.^[6] This project was entitled “Development of environmentally benign and consolidated process for efficient production of cellulosic ethanol.” Our purpose was to boost their bioethanol distillation in the consolidated bio-processing process (called CBP process). The target allocated to the distillation team was (1) to enrich the fermented mash ethanol (5 wt% EtOH) to near azeotropic point (more than 90 wt%), and (2) to reduce the energy consumption required for distillation on dehydrated ethanol basis to 4 MJ/L-EtOH for the standard HIDiC. In the later period of the fourth-term project, the project committee members recognized CF-HIDiC to be safer and more promising and then approved the amended target of the energy consumption to 5 MJ/L-EtOH for the CF-HIDiC.

4.1 Influence of the dirty non-volatile residues contained in fermented mashes

Except for the fermentation byproduct (e.g. acetic acid), the fermented mash liquid produced by the CBP process still contains non-volatile residues (e.g. saccharides, glucans, lignins, ashes) and enzyme proteins even after filtration pretreatment. We had a fouling problem as to how to prevent the fermentation residues from depositing by solidification reaction onto the heat transfer surfaces of the HIDiC stripping section and reboiler. For a preliminary check of fouling, a mash liquid fermented from rice straw was put into our original jacketed tank evaporator (named “Wall Wetter Evaporator”). We conducted the fouling test varying the operating pressure of the evaporator kettle. The inside wall of the evaporator kettle was assumed as the fouled

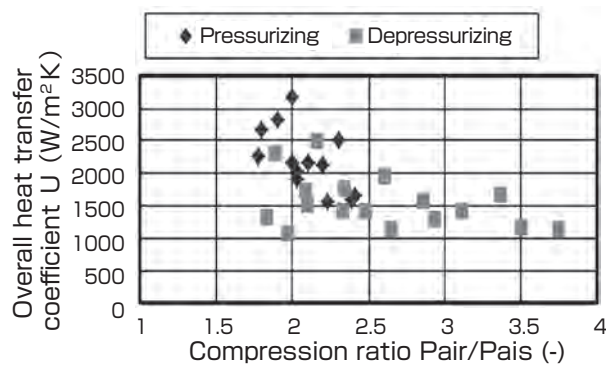

Fig. 8 Variation in overall heat transfer coefficient with compression ratio^[5]

heat transfer surface of HIDiC stripping section and the outer wall on the jacket side was regarded as the clean heat transfer surface of HIDiC rectifying section. Therefore relatively low pressure live steam (0.12 MPa, 104.5 °C) in place of the rectifying section vapor was supplied into the jacket. The left photograph of Fig. 9 suggested that a serious solidification reaction occurred when the test mash liquid was heated at normal pressure (i.e. slightly higher than 100 °C due to boiling-point rise). The inside wall was fouled severely by the solidified substances (e.g. glucans) at normal pressure. On the other hand, as can be seen from the right photograph, this reaction was suppressed very well without fouled solid layer when the pressure was kept at 235 mmHg (boiling point 68.2 °C). This result suggested that the depressurizing mode should be recommended to prevent the HIDiC stripping section from becoming fouled. Another measure for the fouling problem was that live steam should be supplied to the bottoms of the first column of the CF-HIDiC as well as the HIDiC stripping section in place of the two bottom reboilers because two bottom products of the CF-HIDiC became almost water, i.e. with very low ethanol concentration.^[6]

4.2 HIDiC Bench Plant

4.2.1 Process simulation

We conducted a process simulation analysis to determine the practical design specification of HIDiC bench plant. The design specifications and operating conditions determined for the standard HIDiC are shown in Table 1.

It was necessary to introduce the heat transfer conditions based on the actual tray spacing into the simulator (Invensys. PRO/II) based on an equilibrium tray model. The database of the overall heat transfer coefficient and the heat transfer area based on the actual tray-to-tray spacing were utilized with an assumption of tray efficiency. The efficiency of Lift Trays for the stripping section was assumed as 50 % taking into account the experimental data accumulated in the third-term project. This means that one ideal tray has twice the heat transfer area of an actual tray.



760 mmHg

235 mmHg

At temperatures beyond 100 °C, serious fouling (heat transfer impediment) occurred due to deposition of solidified components of mash residues.

No solidification occurred at lower temperatures. No solid substances deposited on to heat transfer wall.

Fig. 9 Inside view of evaporator kettle in fouling test of fermented mash liquid^{[6],[10]}

(When operating pressure was at 235 mmHg, the boiling temperature was 68.2 °C.)

Table 1. Conditions and specifications for process simulation analysis

Column	Double-tube type
Stripping section (inner column)	150 mm ID, 6.8 m
Lift Tray	34 plates, (17 ideal plates)
Plate efficiency (%)	50 (assumed)
Pressure (column top), Pais (mmHg)	Variable
Pressure drop per tray (mmHg)	6.4 (assumed)
Tray-to-tray spacing (mm) (actual plate)	200
Feed plate (ideal plate basis)	#2
Feed plate of rectifier bottom liquid	#1
Rectifying section (outer column annulus)	250 mmID, 5.2 m
Structured packing	13 ideal plates
Pressure (column top), Pair (mmHg)	740
Pressure drop in total (mmHg)	10
Reflux ratio	Variable
Distillation condition	
Feed rate (L/h)	50 (=49.35 kg/h)
initial temperature:	30 °C
ethanol concentration (wt%):	5.0 wt%
feed temperature :	69 °C
Overhead product	
ethanol concentration (wt%)	>90
ethanol recovery (%)	>95
Bottom product	
ethanol concentration (wt%)	<0.1
Heat duty (Live steam instead of reboiler)	
Live steam (0.3 MPa) supply (kg/h)	Variable
Preheater heat duty (live steam supply)	Variable
Cooling duty (overhead condenser),	Variable
Condensation at bubble point,	
740 mmHg	
Internal heat exchange	
Overall heat transfer coefficient (W/m ² K)	54.82
× heat transfer area (m ²) of one tray-to-tray spacing = UA (W/K) (ideal stage basis)	
Number of active stages (Lift tray basis)	25 (#3~#27)
Heat loss	none (assumed)
Dry vacuum pump	Variable
Theoretical power consumption (kW)	

For the purpose of enriching 5 wt% EtOH to near azeotropic concentration (> 90 wt%), the simulation analysis was performed using a trial-and-error method and the result gave 17 ideal plates for the stripping section and 13 ideal plates for the rectifying section. The column diameters of the double-tube HIDiC column were calculated for the condition of feeding 50 kg/h of 5 wt% ethanol-water solution. We can say from a viewpoint of the heat transfer area that the larger the column diameter the better the rate of energy saving. Owing to such circumstances, the inside diameters of the inner and outer columns were determined as 150 mm and 250 mm, respectively, so that the F-factor based on superficial vapor velocity could lie in a relatively low F-factor range of 0.05 < F < 0.7. Because this F-factor was considerably small, the tray-to-tray spacing was determined as 200 mm using the Lift Tray database. Therefore one ideal plate having 400 mm of tray spacing has a heat transfer area of $A_i = 0.1885 \text{ m}^2$. The clean rectifying section was filled with structured packing. The part of internal heat exchange in the stripping section was positioned between #3 and #27 actual plates (25 Lift Trays in total), which was in thermal contact with the same height part of the rectifying section. Taking into

account the overestimated heat transfer area based on the actual tray spacing, the overall heat transfer coefficient was underestimated instead as $U = 250 \text{ kcal/m}^2\text{hr}^\circ\text{C} = 290.75 \text{ W/m}^2\text{K}$ from a viewpoint of the fouling effect. As the simulation analysis condition, the operating pressures of the HIDiC rectifying and stripping sections were specified as 740 mmHg and 210 mmHg, respectively. The simulation result is shown in Fig. 10.

As the necessary rate of 0.3 MPa live steam supplied into the bottom of the stripping section, we obtained 0.88 kg/h, which corresponded to the heat duty $Q_{STM} = 2.15 \text{ MJ/h}$ in place of the bottom reboiler. The heat duty for the preheater was $Q_{preh} = 2.35 \text{ MJ/h}$. The theoretical power consumption of the dry vacuum pump was obtained as 0.7 kW. Assuming 40 % as

vacuum pump efficiency, the power requirement amounted to $E_{VP} = (0.7/0.4)(3600/1000) = 6.3 \text{ MJ/h}$. The volumetric flow rate of ethanol involved in the feed rate 50 kg/h was $V_{EtOH} = 3.16 \text{ L/h}$ on the dehydrated ethanol basis. The energy consumption required for producing 1 L of dehydrated ethanol by distillation was calculated as $(Q_{STM} + E_{VP} + Q_{preh})/V_{EtOH} = 3.42 \text{ MJ/L-EtOH}$. This result successfully indicated a possibility of attaining the target of energy saving by the bench plant.

4.2.2 System design and test operation result of HIDiC bench plant

As shown in Fig. 11, the bench plant was designed so as to investigate two kinds of HIDiC flow systems: (1) the standard HIDiC system using a dry vacuum pump and (2) the

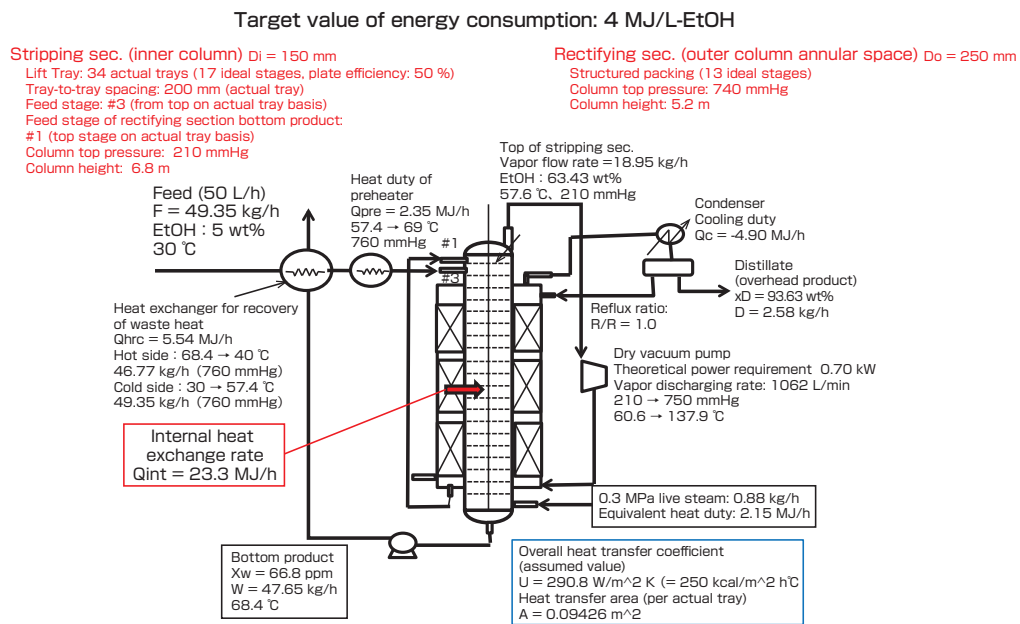

Fig. 10 Bench plant design specifications determined by process simulation analysis^[6]

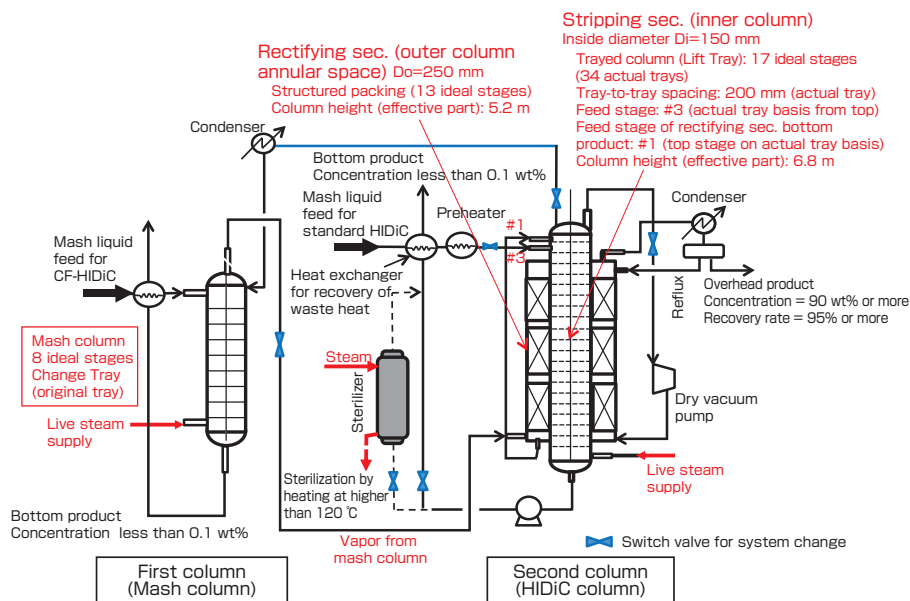

Fig. 11 Flow system of HIDiC bench plant^[6]

compressor-free HIDiC system consisting of two columns: the first one was an ordinary column and the second one was a HIDiC main column. The project committee recognized the CF-HIDiC system as promising for a large-scale commercial plant, and recommended to add it to the project plan.

(1) Standard HIDiC

Figure 12 shows a flow system for the standard HIDiC used in the bench plant. In the early period, the main plan of our team was to investigate the standard HIDiC because of its great energy saving effect. Being distinct from a usual HIDiC system, the stripping section was placed into the inner column for maintenance of removing solidified substances and residues from fouled trays. The clean rectifying section filled with structured packing was placed into the annular space of the outer column. The stripping section was

equipped with our Lift Trays for prevention against tray blockade.

We had to conduct the test operation of the bench plant using a simulated mash liquid owing to the fact that the bioprocess team had not yet reached the stage of full production. As shown in Fig. 13, we obtained a satisfactory result of the standard HIDiC test operation at a small reflux ratio of 0.378 when the stripping section was depressurized to 225 mmHg with the rectifying section kept at normal pressure. The result satisfying the project target can be summarized as follows: (1) sufficient ethanol concentration of overhead product of 94.4 wt%, i.e. higher than the project target (> 90 wt%) with reflux ratio of 0.378, (2) large recovery rate of 95.4 % of ethanol contained in the feed, i.e. higher than the project target (> 95 %), (3) sufficiently low ethanol concentration of

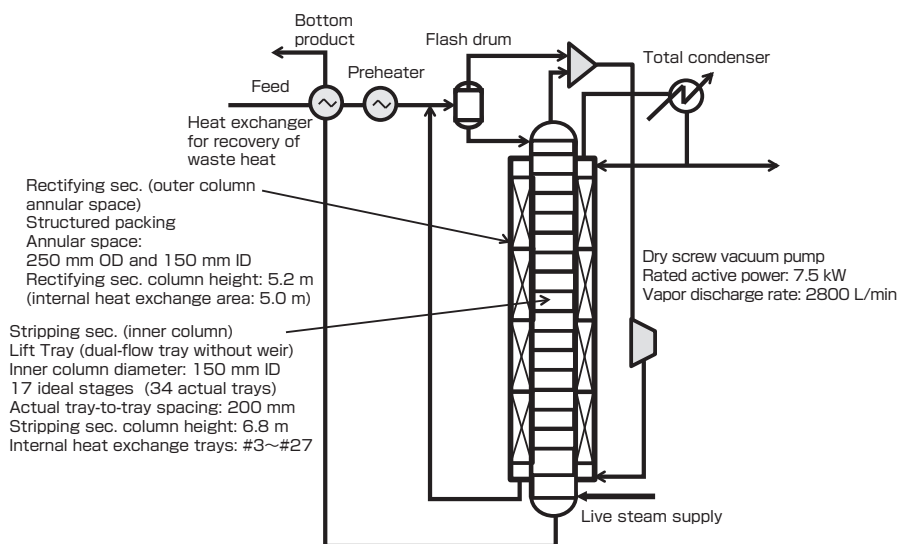

Fig. 12 Structure of standard HIDiC bench plant^{[6][7][10]}

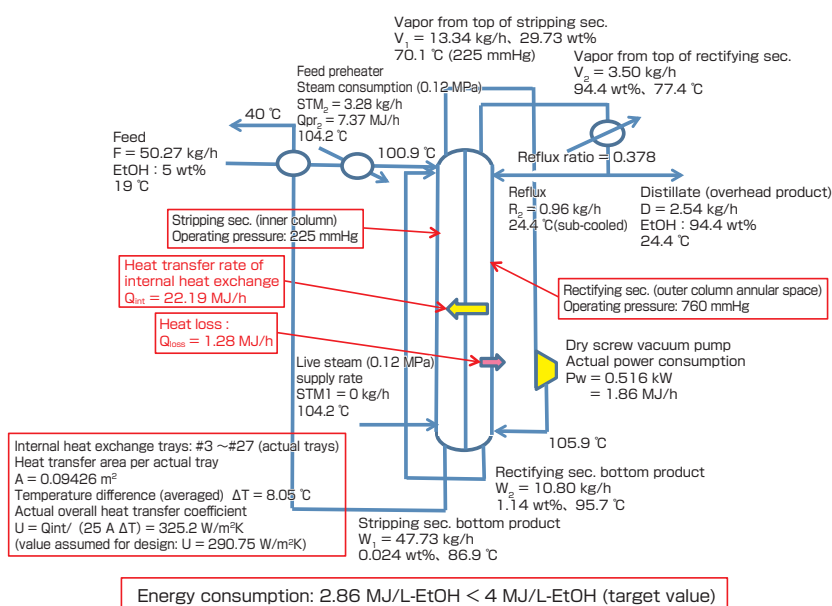

Fig. 13 Test run result of standard HIDiC bench plant^{[6][7][10]}
(obtained when $P_{air} = 760 \text{ mmHg}$ and $P_{ais} = 225 \text{ mmHg}$)

the bottom product of 0.024 wt%, i.e. lower than the target (< 0.1 wt%), and (4) no supply of live steam into the bottom of the stripping section ($Q_{STM} = 0$ kg/h). This implies that the standard HIDiC column could be driven only by the dry vacuum pump without any heat duty. The electric energy actually consumed by the dry vacuum pump was $E_{VP} = 0.516$ kW = 1.86 MJ/h. In this case, a heat duty of the preheater was required as $Q_{preh} = 7.37$ MJ/h. The total energy consumption amounted to $Q_{total} = Q_{STM} + E_{VP} + Q_{preh} = 9.23$ MJ/h. As the energy consumption required for producing 1 L ethanol on dehydrated ethanol basis, $Q_{total}/V_{EtOH} = 9.23/3.16 = 2.87$ MJ/L-EtOH. This result was sufficiently smaller than the project target (4 MJ/L-EtOH).

(2) Compressor-free CF-HIDiC

In the latter period of the fourth-term project, this CF-HIDiC was added as a promising system applicable to large commercial-scale plants because neither compressor nor vacuum pump was necessary. This two-column HIDiC system having an ordinary mash column as the first column in place of a compressor is also incorporated into the bench

plant shown in Fig. 11.

The mash column (first column) was equipped with 16 trays of our original Change Trays (corresponding to 8 ideal plates). The Change Tray was regarded as an advantageous, very tough tray suitable for the mash column. As shown in Fig. 18 (right), the Change Tray had two separate parts of a Lift Tray, which consisted of a circular disc (inner plate) and an annular disc (outer plate) manufactured by cutting a Lift Tray. The inner plate could be operated from the outside to vary the tray opening area depending on the degree of tray blockade.

The double-tube HIDiC column was utilized without a dry vacuum pump as the main column of CF-HIDiC. Keeping the mash column and the HIDiC rectifying section at normal pressure, the HIDiC stripping section was depressurized by the water-sealed vacuum pump of the stripping section overhead condenser. Figure 15 shows the test operation result obtained when the HIDiC stripping section reached 345.5 mmHg. In this case, the feed preheater was operated

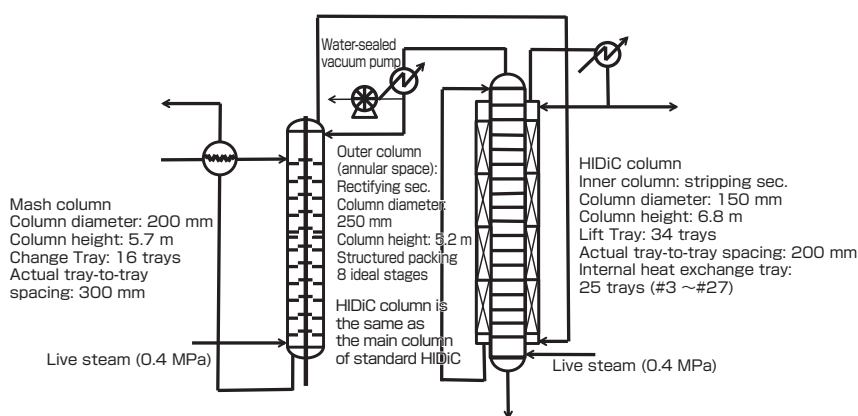

Fig. 14 Flow system of CF-HIDiC bench plant^{[6][7]}

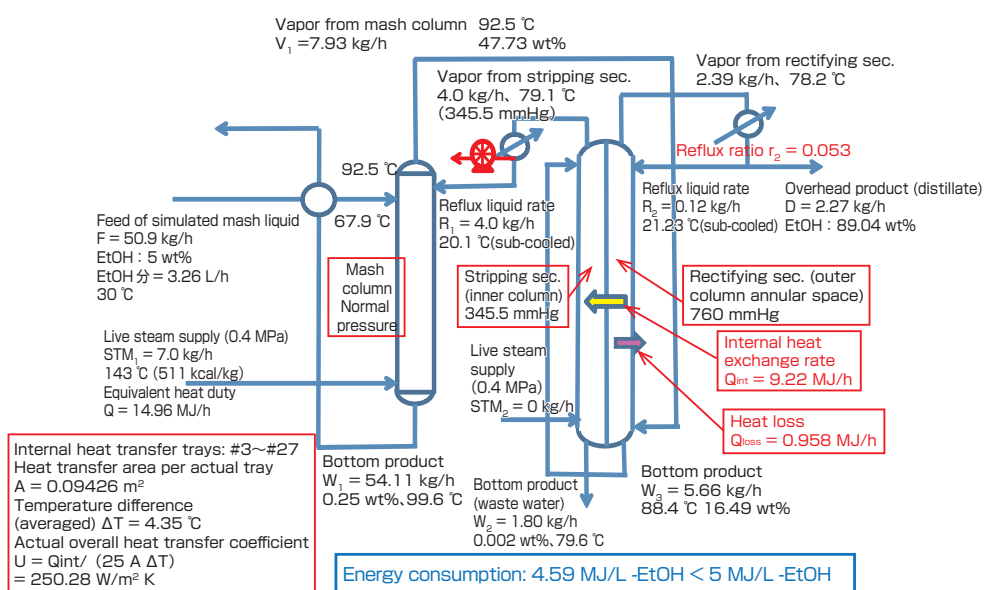

Fig. 15 Test run result of CF-HIDiC bench plant^{[6][7]}
(obtained when live steam supply to mash column was 7.0 kg/h)

by utilizing the thermal energy of the mash column bottom product as waste heat. The rate of 0.4 MPa live steam supplied into the mash column bottom amounted to 7.0 kg/h corresponding to $Q_{STM1} = 14.95$ MJ/h as the heat duty.

The HIDiC main column was successfully operated with no live steam supply owing to a great effect of internal heat exchange. This means that the heat duty of the HIDiC main column became $Q_{STM2} = 0$ MJ/h. As a result, the whole CF-HIDiC system was successfully operated by the live steam supply for the mash column only: $Q_{total} = Q_{STM1} = 14.95$ MJ/h.

Taking into account the volumetric feed rate of ethanol $V_{EtOH} = 3.26$ L/h, the energy consumption required for the whole CF-HIDiC system amounted to $Q_{total}/V_{EtOH} = 4.59$ MJ/L-EtOH on dehydrated ethanol basis. This value suggested that the project target (< 5 MJ/L-EtOH) was successfully achieved. However as can be seen from Fig. 15, the ethanol concentration 0.25 wt% of the mash column bottom product went beyond the effluent control value (0.1 wt%) and the overhead product concentration 89.04 wt% became a little bit lower than the project target (> 90 wt%). We had to gradually increase the rate of live steam supply into the mash column from 7.0 kg/h.

Figure 16 indicates that we obtained an optimum result satisfying both the energy-saving target and the enriching target when the live steam supply was raised to 10.55 kg/h. The CF-HIDiC test operation was a big success with the following results: (1) energy consumption of 5.09 MJ/L-EtOH was almost on par with the project target (5 MJ/L-EtOH), (2) overhead product concentration of 92.2 wt% EtOH and the two bottom product concentrations 0.01 wt% and almost 0 wt% satisfied the respective target values (> 90 wt% and < 0.1 wt% EtOH), and (3) recovery rate of 95.8 % of ethanol contained in

the feed was also larger than the target value (95 %).

Finally the photograph of the bench plant is shown in Fig. 17, where the right-side column is the first column (mash column) and the left-side one is the double-tube HIDiC trayed column. Figure 18 shows the internal structures of the two columns: the left photograph indicates a Lift Tray installed into the stripping section and structured packing installed in the rectifying section; and the right photograph indicates the Change Tray equipped into the mash column. The upper plate of the Lift Tray had an opening of square holes while the lower fixed plate had circular drilled holes. Considering the variation of vapor rate with the height of the HIDiC stripping section, the number of holes of the Lift Trays was adjusted.

5 Conclusion

Starting with a project of the New Sunshine Program “the fundamental research on energy saving distillation technology by internal heat integration,” we participated in three successive NEDO projects spanning over more than ten years. The useful outcome obtained by this substantive research suggests that the road to commercialization is not a long way off.

In spite of the great effect of energy-savings, the HIDiC technology still did not spread in the chemical industry. This is due to the fact that usual steam temperature level of the heat source for distillation is not so high to try an improvement of distillation processes from a viewpoint of energy conservation. The standard HIDiC is suitable to clean distillation processes because of its great effect of energy savings. However a technological problem still remains as to whether or not a big compressor is necessary for a large

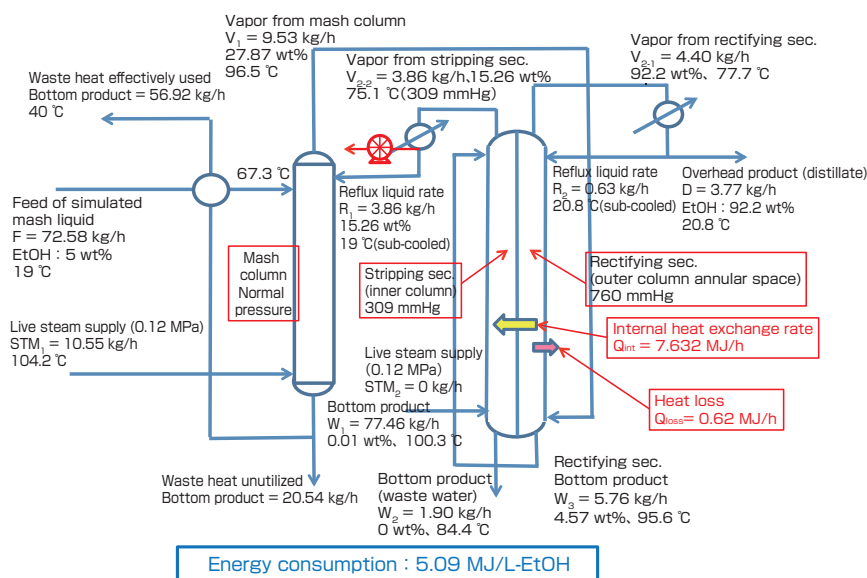

Fig. 16 Test run result of CF-HIDiC bench plant^[6]
(obtained when live steam supply to mash column was 10.55 kg/h)

discharging rate of distilled vapor. At the present time, in particular, there is not an appropriate vacuum pump available for the depressurizing mode. It can be considered that the CF-HIDiC with no compressor is appropriate for large-scale distillation plants. We are expecting wide spread use of CF-HIDiC in various fields of the chemical industry.

Acknowledgments

This research was conducted through the following successive projects supported by the New-Energy and Industrial Technology Development Organization (NEDO), Japan

- ① NEDO project No.P02020: Eco-energy distillation technological development by internal heat integration (FY2002 – FY2005)
- ② NEDO project No.P09015: Strategic development of energy conversion technology/research and development of basic technologies for an internally heat integrated distillation column compressor-free system (FY2008 – FY2010)
- ③ NEDO project No.P07015: Development of environmentally benign and consolidated process for efficient production of cellulosic ethanol (FY2008 – FY2010)

We would like to express our gratitude to AIST (National



Fig. 17 Bench plant of CF-HIDiC under installation^[10]
 mash column (right) and HIDiC main column (left)

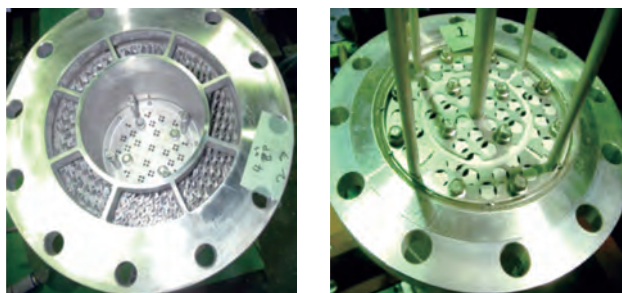

Fig. 18 Internal structure of mash column (right) and HIDiC main column (left)^[10]

Lift Tray type of Change Tray (right) and Lift Tray (inner column) and structured packing (annular space) (left)

Institute of Advanced Industrial Science and Technology) for the valuable advice given in the early period of constructing the HIDiC database.

This project was successfully shortlisted as one of the five candidates for the best project of the year 2013 in the global awards of IChemE, UK.

References

- [1] M. Nakaiwa and T. Ohmori: Innovation in distillation processes, *Synthesiology*, 2 (1), 51-59 (2009) (in Japanese) [*Synthesiology English edition*, 1 (1), 55-63 (2009)].
- [2] NEDO Project: Naibu-netso-kokan ni yoru sho-ene joryu gijutsu-kaihatsu (Technological development of energy-saving distillation column by internal heat integration) (Project No. P02020), (FY2002 – FY2005), Final Report (2006) (in Japanese).
- [3] K. Horiuchi, K. Yanagimoto, K. Kataoka and M. Nakaiwa: Energy-saving characteristics of heat integrated distillation column technology applied to multi-component petroleum distillation, *Distillation & Absorption 2006*, Inst. Chem. Eng. Symp. Ser., 152, 172-180 (2006).
- [4] Patent No.4819756 (2011): Taseibunkei naibu-netsokokan-shiki joryu-sochi (Internal heat integrated distillation system for multi-component distillation).
- [5] NEDO Project: Enerugi shiyo gorika gijutsu senryakuteki kaihatsu/Asshukuki o hitsuyo to shinai naibu-netso-kokan-shiki joryu shisutemu no kiban-gijutsu no kenkyu-kaihatsu (Strategic development of energy conservation technology/research and development of basic technologies for an internally heat integrated distillation column compressor-free system (Successive research phase) (Project No.09015) (FY2008 - FY2010) Final Report (2011) (in Japanese).
- [6] NEDO Project: Serurosu etanoru ko-koritsu seizo no tameno kankyo-chowagata togo purosusu kaihatsu (Development of environmentally benign and consolidated process for efficient production of cellulosic ethanol) (No.P07015) (FY2008 – FY2010) Final Report (2011) (in Japanese).
- [7] K. Kataoka, H. Noda, H. Yamaji, T. Mukaida, K. Kurata, M. Kaneda and G. Nishimura: Baio-etanoru noshuku no tameno asshukuki fuyo no HIDiC --- Benchi puranto ni yoru jissho kenkyu (Substantive research on a compressor-free HIDiC bench plant for enrichment of bioethanol), *Autumnal Meeting of SCEJ*, M108 & 109, Okayama, September 16-18 (2013) (in Japanese).
- [8] R. S. H. Mah, J. J. Nicholas Jr. and R. B. Wodnik: Distillation with secondary reflux and vaporization: A comparative evaluation, *AIChE Journal*, 23 (5), 651-658 (1977).
- [9] H. Noda, K. Kataoka, H. Yamaji and N. Kuratani: Heat transfer and flow characteristics of a double-tube HIDiC trayed column, *8th World Congress of Chemical Engineering*, energy 0064, Montreal, August 23-27 (2009).
- [10] K. Kataoka, H. Noda, T. Mukaida, G. Nishimura and H. Yamaji: Boost to bioethanol distillation by internal heat-integrated distillation column (HIDiC), *Advanced Chemical Engineering Research (ACER)*, 3, 48-57 (2014).

Authors

Kunio KATAOKA

Graduated from Department of Chemical Engineering of Kyoto University in March 1963. Completed the courses at Graduate School of Engineering, Kyoto University in March 1968. Doctor of Engineering. Assistant Professor of Chemical Engineering Department, Kobe University in April 1968. Associate Professor, Kobe University in May 1971. Invited Professor, Department of Chemical Engineering, Louisiana State University in August 1978. Full Professor, Kobe University in October 1988. The Dean of Engineering, Kobe University in April 1994. The Vice President of Kobe University in February 1997. The President of the Society of Chemical Engineers, Japan (SCEJ) in April 2000. Won the Award of Science of Hyogo Prefecture in November 2001. Won the SCEJ award 2003 from the Society of Chemical Engineers, Japan in 2003. After retirement from Kobe University in 2013, joined Kansai Chemical Engineering Co., Ltd. (KCE) as the Executive Director in April 2003. Currently, Director of R&D Laboratory of KCE and Executive Director of Bio-energy Corporation. Executed NEDO HIDiC projects P02020, P09015 and P07015 successively from 2003 to 2011. Interested in the fields of transport science and heat transfer both for research and education in Kobe University period. Now interested in the development of energy conservation technologies in chemical engineering processes in the present KCE period. Honorary members of SCEJ and HTSJ (Heat Transfer Society of Japan). In this paper, contributed to development of CF-HIDiC as chief leader of the third-term project. Contributed not only to basic technological development and database construction of HIDiC but also to practical design of the HIDiC bench plant based on the specifications and operating conditions determined by process simulation analysis. Contributed to the negotiation with other project teams for fixing up all the targets of individual sub-teams for the objective of the whole Biofuel Challenge NEDO project.



Hideo NODA

Graduated from Department of Physics, Osaka University in March 1970. After joining Kansai Chemical Engineering Co., Ltd. (KCE) in 1970, completed the courses at Graduate School of Chemical Engineering, Osaka University in March 1975. Doctor of Engineering. Visiting researcher, University of Leeds from 1979 to 1981. President of KCE in 1993. In addition, founded Bio-energy Corporation as President in 2001. Won the Award of Science of Hyogo Prefecture in November 2011. Currently a Director of SCEJ from 2013. Interested in various distillation technologies, HIDiC, Wall-Wetter, crystallization and biofuel processes and systems from 1990. Executed this NEDO project of bioethanol production process as the project sub-organizer, researching bio-reactors from 2001. Won many various awards of technologies from SCEJ and SSPEJ (The Society of Separation Process Engineers, Japan). In this paper, as the sub-organizer of NEDO project No.P02020, responsible for allotting individual energy consumption as project targets to all the sub-processes



producing bioethanol. Members of SCEJ, SSEJ, SBJ (The Society for Biotechnology, Japan) and others.

Discussions with Reviewers

1 Overall

Comment (Yasuo Hasegawa, AIST Kansai, and Akira Kageyama, Research and Innovation Promotion Headquarters, AIST)

Focusing their attention on distillation technology as the main separation process in chemical industry, the authors executed successive NEDO projects for ten years for the development of the internal heat integrated distillation column (HIDiC) in expectation of a great effect of energy conservation. They successfully broke through a barrier against spreading of the standard HIDiC by analyzing its negative factor. This paper describing the process of how to execute their successive projects for the research and development based on a definite scenario is suitable for *Synthesiology* and is useful to researchers in other fields.

In order to achieve the primary purpose and project target, they not only realized a collaboration of process system engineering with heat transfer engineering for mutual complementation of different technological fields but also proposed cooperation with the team of saccharification and fermentation.

We judge this paper to be full of suggestions on methodology of research and development and project management.

Answer (Kunio Kataoka, KCE)

Responding to the objective of *Synthesiology*, the reviewers advised us to rearrange the chapters of the paper from a viewpoint of methodology as to how to execute projects for breakthroughs. We rewrote the paper complying to the purport of their questions and comments. This successful accomplishment was not only due to the fact that these successive ten year-lasting projects were accepted by NEDO but also due to the valuable discussions and advice given by various professors and researchers from a wide range of scientific fields.

It was good that we courageously acknowledged our inexperience and collaborated with researchers of different fields, and created an atmosphere of active discussion at project meetings with researchers from various fields. We would like to emphasize that the way to command a big project is to synthesize comprehensively with the collaboration of people from many different fields.

2 Technological issue of distillation for clean and dirty services

Question (Yasuo Hasegawa)

We always ask authors to rewrite their papers along the purport of *Synthesiology*, so that inexperienced readers from different fields can understand as much as possible. If the authors supplement the following, the paper will become more comprehensible.

In the second-term project, a packed-column type HIDiC system allotted by Kimura Chemical Plants was adopted as a candidate of the pilot plant. At that stage, how was the packed-column HIDiC system evaluated in relation to the development level? What was regarded as a clean service of distillation? What degree of energy saving was expected? What was a dirty service of distillation which is covered in this paper? We want you to give some explanations why the packed-column system could not be used for a dirty service. In addition, an original idea leading to HIDiC was proposed by Dr. Mah *et al.* In spite of that, their paper was hardly noted and was not followed by anybody. Why

was their paper left buried? We would like to know what kind of technological difficulty caused such a resigned situation.

Answer (Kunio Kataoka)

Taking into consideration these questions, we rewrote this paper with some additions and modifications. First of all, the first- and second-term projects were started with investigation of a packed-column type HIDiC system, because most of the leading investigations of distillation were preceded by universities and their experimental data of packed-column distillation were rich in content. Regarding the clean service of distillation, therefore, if the hydrocarbon mixtures mostly treated in petrochemical industry contain neither distillation residues (e.g. pitches) nor polymerizable substances, there is not any fear of corrosion, solid deposition and blockage of internal packing. Then a packed-column type HIDiC system was regarded as the most reliable candidate for an HIDiC pilot plant.

On the other hand, regarding the dirty service of distillation, there are various kinds of feed mixtures for distillation. For example, the dirty mixtures very often contain intrinsically solid suspended substances (e.g. pigments, catalysts, carbonized substances, ashes, etc.). A solution including monomers not only may increase in viscosity during the distillation process but may also cause tray blockage owing to the polymerization or solidification reaction. There also is another dirty mixture containing dissolved inorganic salts (e.g. calcium sulfate) which produces crystal particles depositing on heat transfer surfaces when temperature rises. These mixtures have a fear of blocking internal packing which makes the maintenance of a packed-column type HIDiC system impossible. This situation aroused our interest in the need of development of another type of HIDiC system. Although we did not make an analysis strictly investigating why Dr. Mar *et al.* paper was left buried, we extracted the following factors: (1) their paper was presented at a place not noticeable for researchers in the distillation engineering field, (2) distillation engineers were not inexperienced and felt uncomfortable about mechanically compressing a large volume of vapor in the distillation process when considering preventive measures for fire, and (3) their paper written using a block diagram of black boxes from a viewpoint of process system engineering did not show a practical image of the system structure of internal heat integration. Therefore we may say that at that time, distillation engineers were not able to figure out any possibility of realization.

3 Originality of developed technology

Question (Akira Kageyama)

This paper mentions that it was an original idea to reflux a condensate produced at the overhead condenser of the HIDiC stripping section to the top of the first column. You also describe that your original Lift Trays were placed in the second column of the CF-HIDiC system. Does this mean that no similar equipment had been in existence up to that time? We would like you to discuss the originality of the developed technology in more detail.

Answer (Kunio Kataoka)

We added some postscripts to the paper in relation to this question. In the stripping section of the HIDiC column, the upward flowing vapor is increased owing to the partial vaporization due to the internal heat exchange in order to reduce the heat duty of the bottom reboiler. Nevertheless the vapor arriving at the top of the stripping section is condensed purposely by the overhead condenser. Many contrary opinions were expressed pointing out that the idea of an overhead condenser of the stripping section was against the rule of the original HIDiC concept. We repeated the following explanation in relation to the origin of our idea. The first column of CF-HIDiC is an ordinary column but does

not have an overhead condenser. The overhead condenser of the HIDiC stripping section can substantially be regarded as the first column condenser because its condensate is refluxed to the top of the first column. The first column does not have any effect of energy saving but has an important role in supplying pressurized vapor into the bottom of the HIDiC rectifying section. We emphasized by using the process simulation that the CF-HIDiC system accompanied the first column could still give a great effect of energy saving without a compressor.

The advisory committee understood our idea of CF-HIDiC and gave their consent after a long discussion, and then the counterarguments gradually dissolved. This was a big breakthrough in our project.

We still think that this unique idea would not have been reached without the collaboration with a researcher of heat transfer engineering who was inexperienced in distillation engineering. He was outside the bounds of common sense in distillation.

We can say that the switchover of conception was a key point to the breakthrough. There was no other distillation tray available similar to the Lift Tray when it was invented. The Lift Tray is a set of two perforated plates, the upper one of which can be lifted automatically to float in response to variation in vapor flow rate passing through drilled holes of the perforated plate. This action can control the tray pressure drop due to an increase in the opening area for vapor flow because the layout of drilled holes of the upper plate is shifted from that of the lower plate. The Lift Tray is still utilized widely as a unique tray with its self-controlling function against pressure drop.

4 Collaborative fusion with different technological fields

Question & Comment (Akira Kageyama)

A collaborative fusion was made between process system engineering and heat transfer engineering beyond the system boundary of the scientific field of chemical engineering. This action led to a most important breakthrough. As a result, taking notice of the product UA of the overall heat transfer coefficient and the effective heat transfer area as the main control parameter, the mixed team of the project successfully constructed a useful design database by observing the characteristics of internal heat integration under a distillation condition. This paper mentions that such kind of collaborative fusion resulted in an important methodology for a breakthrough of the most important subject of the project. In what stage of discussion was such a proposal brought forward? Is it possible to describe the importance of going beyond boundaries of scientific fields for a collaborative fusion?

Answer (Kunio Kataoka)

As mentioned in the paper, one of the authors, K. Kataoka, was invited as an expert of heat transfer engineering into the advisory committee organized with experts of process system engineering and engineers of practical distillation plants. The committee had a long, active discussion about the following items: (1) why distillation engineering usually consisting of process system engineering and thermodynamic vapor-liquid equilibrium theory was insufficient to execute the HIDiC project, (2) heat transfer engineering deals with transport phenomena on the heat transfer surfaces resting on the basis of non-equilibrium theory, (3) an approach based on heat transfer engineering has a possibility of grasping and breaking through the essence of the matter, and (4) how the usual approach by distillation engineering should be combined with that of the heat transfer engineering approach. This can also be considered as a very significant discussion from the viewpoint of *Synthesiology*. As a result of

discussion, the difficult issues in deadlock were compromised and how to construct a simple database for utilizing practically applicable, useful parameters was discussed. Different from an ordinary column, the characteristic data of heat transfer taken in the condition of a running HIDiC system was compiled in the form of overall heat transfer coefficient and temperature difference as a function of the compression ratio. As a result, a practically useful design concept of HIDiC based on heat transfer engineering was successfully constructed.

Generally speaking, distillation process proceeds with vaporization of more-volatile components due to the latent heat released in condensation of less-volatile components, that is, it is the phenomenon of simultaneous heat and mass transfer.

Half a century ago, from this viewpoint, AIChE Research Committee took on a big project for the "Construction of a practical design and analytical method of trayed columns" using a concept of mass transfer similar to gas absorption (Tray Efficiencies in Distillation Columns, 1958 and Bubble-Tray Design Manual 1958). Their outcomes were very attractive at that time but were not utilized widely for practical use. This was due to the fact that the mass transfer occurring in the distillation process was very complicated in generalizing accumulated data. Therefore even at the present time, the analysis and design method of distillation columns is still based on the ideal plate model and the thermodynamic vapor-liquid equilibrium theory rather than the transport theory.

The gap between the equilibrium theory and non-equilibrium theory is made wider by the HIDiC system accompanied with internal heat exchange. A big breakthrough toward completion of the design method was brought about by introducing the heat transfer coefficient data and an assumed tray efficiency into a process simulator based on the modeling of process system engineering with the ideal plate model. The design specifications of the bench plant were determined by the process simulation analysis. We can say that the establishment of this design method led to success.

5 Mutual complementary cooperation with the fermentation technology team

Question and comment (Akira Kageyama)

Subchapter 2.6 describes a negotiation with the group of saccharification and fermentation. The distillation team brought an argument forward with the bioprocess team using the process simulation result of Fig. 3. I think that this is a good, creative idea leading to a breakthrough. As a result of the discussion, the whole

project group reached an agreement about the common purpose and target for the breakthrough of the project.

Mutual understanding between researchers in different technological fields broke through the common subjects of interest. These actions can be considered very important as a trigger for innovation or inventing a new technology. I would like you to describe in more detail. In addition, the issue whether or not the team of saccharification and fermentation gained the project target of 5 wt% ethanol was very essential information just as much as the CF-HIDiC result of the distillation team. This information is very important in conveying to the readers the degree of accomplishment toward JPY40/L-EtOH as a successful outcome.

I would like you to describe up to what wt% the bioprocess team was able to raise the mash ethanol concentration in the end.

Answer (Kunio Kataoka)

The bioprocess team was very diligent in developing a very efficient saccharification and fermentation process by using novel genetic manipulation and yeast-based cell-surface display technologies. The mash ethanol concentration reported at that time amounted to 2 wt% at the highest. However the most important target (production cost) of the project was JPY40/L-EtOH. In order to attain this goal, 4 MJ/L-EtOH was allocated as the energy requirement for the standard HIDiC system. For the CF-HIDiC system dealt in this paper, 5 MJ/L-EtOH was given to the distillation team. We emphasized the following issue at the project meeting: (1) there is a problem of fouling resulting from fermentation residues and (2) unless the mash concentration of ethanol reaches 5 wt%, it is very difficult to attain the project target even by the HIDiC technology which was regarded as the most promising energy-saving distillation at that time. As you pointed out, Figure 3 indicates the simulation result analyzing the energy requirement as a function of mash ethanol concentration. We could not have had an agreement at the meeting without this precise explanation based on our own database. We added a postscript about this.

On the other hand, the team of saccharification and fermentation extracted a CBP yeast appropriate as the host cell by screening more than 600 strains. They succeeded in cell-surface display of xylase and cellulase on the surface of that yeast. As a result, they successfully constructed the process/system of simultaneous saccharification fermentation producing higher than 5 wt% EtOH fermented mash from pretreated biomass. Finally the ultimate purpose of the whole project was achieved as a result of the respective targets being reached through cooperation of the distillation process team with the bioprocess team.

Secure password authentication schemes and their applications

— How to achieve security with short passwords —

Kazukuni KOBARA * and SeongHan SHIN

[Translation from *Synthesiology*, Vol.7, No.3, p.179-189 (2014)]

Passwords are widely used for encrypting files, authenticating remote users on a communication network, and establishing encrypted channels for authenticated users. However, the possibility of passwords being stolen or abused raises security problems, and having to remember a number of lengthy passwords is often inconvenient. The purpose of this research is to develop new schemes to resolve these problems and make them generally available to society. In this paper, we introduce our research strategies and scenario to achieve this purpose.

Keywords : Authentication, key management, password, phishing, cloud

1 Introduction

1.1 Background

Passwords are used for many wide-range purposes to identify users on the network, to perform remote user authentication for establishing an encrypted communication channel with such users, to encrypt files, and so on. However, passwords have many problems of security such as being stolen and abused or of inconvenience in remembering several long passwords. Improvements are sought for such issues.

On the other hand, there are methods other than using passwords to identify an individual, such as using biometrics or personal belongings. The biometric authentication has problems such as impersonation using artificial materials, low identification capability, and requirement of a special device to detect artificial impersonation,^[1] and research to improve such issues is currently in progress. The authentication method using personal belongings should be combined with passwords to prevent abuse in case the object is stolen or lost, and it is not necessarily a complete replacement to the password method. For file encryption, there are methods of using the encryption keys instead of passwords, but the password is necessary to protect the decryption keys. Although there exist methods using information other than passwords, they are not complete replacements to the password method at this moment. Therefore, in this research, we aim to solve the problems of passwords by focusing on improvements of the methods handling the passwords.

Figure 1 shows the statistical data^[2] published by the National Police Agency pertaining to the password security problems. Here, “lax setting and management of password” means that

the password was cracked due to exhaustive searches because an easily guessed password was used. “Former employees, acquaintances, etc.” means that the crime was committed by individuals such as the server manager who had the right to access to the victim’s password. The former case will be explained in detail in subchapter 1.2. For the latter case, it has been a problem that a third party can know the password by using the information leaked from the server, and this problem will be explained in subchapter 1.3. As countermeasures to “heard or peeked” and “lax setting and management of password,” it is recommended to employ two-factor authentication where information other than passwords is used concurrently, in addition to alerting and educating the users. However, as the two-factor authentication becomes more prevalent, the resistance against loss and theft of client devices becomes important, and this will be explained in subchapter 1.4. Finally, the problem of phishing fraud will be discussed in subchapter 1.5.

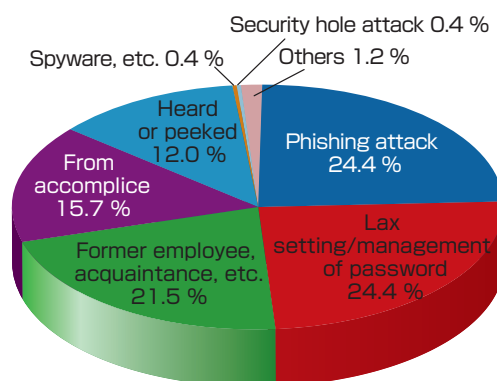

Fig. 1 Ways of obtaining passwords

Research Institute for Secure Systems (RISEC), AIST Tsukuba Central 2, 1-1-1 Umezono, Tsukuba 305-8568, Japan
* E-mail: kobara_conf@miaist.go.jp

Original manuscript received October 24, 2013, Revisions received January 14, 2014, Accepted April 3, 2014

Table 1. Comparison of remote user authentication methods using passwords

		Security against password exhaustive searches			Security against phishing attacks	Number of passwords
		Against eavesdropping and impersonation	In case of stored information leakage			
Authentication methods			From client	From server	From both with time lag	
One-factor authentication	Conventional protocol using password only	×	○	×	×	×
	PAKE	△	○	×	×	○
	PKI server authentication + PW	△	○	×	×	×
Two-factor authentication	PKI server authentication + PW + OTP	○	○	×	×	×
	PKI (mutual authentication)	○	×	○	×	△
	LR-AKE (this research)	○	○	○	○	○

Table 1 is a summary of the comparison of remote user authentication methods using passwords. The column on the furthest left of the table shows the methods, and these can be roughly divided into one-factor authentication where passwords only are used and two-factor authentication where passwords and stored information are used. Note that these methods not only authenticate the user, but also have the function of establishing an encrypted communication channel between the user and the server. Briefly explaining the outline of each method, the “PKI (public key infrastructure) server authentication + PW (password)” and “PKI server authentication + PW + OTP (one-time password)” are methods where the server has a pair of public key and private key, the encrypted communication channel is established between the client device and the server using the public key, and that encrypted communication channel is used to transport the user’s password or one-time password (OTP) to the server. If the public key is considered to be an authentication information that must be managed by the user, it will be two-factor authentication, while if it is considered to be information that does not have to be managed by the user, it will be one-factor authentication. In many cases, the latter form of management is taken, and this is one of the technological security holes that allow phishing fraud. This problem will be explained in subchapter 1.5. The one-factor authentication that uses passwords only can be categorized into “conventional protocol using password only” and “password authenticated key exchange (PAKE).” The former has disadvantages of being susceptible to eavesdropping on the communication channel and impersonation, but PAKE solved these issues. However, in these methods, the password or its hash value (value to which the password is processed) that is used to authenticate the user must be stored on the server, and is susceptible to leakage of information. Moreover, if the user uses the same password in multiple servers, the password that was leaked due to a problem in one server can be used to log in to a server or service that is presumed to be secure. In order to prevent this problem, the user must set different passwords for each service, and must remember multiple passwords as shown in the last column of

Table 1.

The PKI mutual authentication is a method resistant against information leakage from servers. In this method, both the server and the user have a pair of public and private keys, and the user’s public key (or related information) is stored on the server. Therefore, even if the information leaks from the server, the private key needed for impersonation cannot be obtained. However, since the private key is stored on the client side in this method, it is weak against the information leakage from the client. This issue will be explained in subchapter 1.4. The leakage-resilient authenticated key establishment (LR-AKE) is a method that was devised and practically applied through this research. The user uses only one short password, yet this system is resilient to eavesdropping, impersonation, leakage of stored information from either the server or the client, phishing, and others.

The aforementioned problems and the items in the remaining columns of Table 1 will be explained in the following subchapters.

1.2 Vulnerability against exhaustive searches of passwords

The most basic method for increasing resilience against password exhaustive searches is to use an extremely long password that is randomly selected. However, this method substantially reduces usability and is not practical. Therefore, a way must be considered to increase resilience against exhaustive searches while using a short password that is within the range in which a person can remember it effortlessly. Although this may seem to be a paradoxical issue, the solution may arise if one can understand that the password exhaustive searches can be categorized into an offline exhaustive search, a parallel online exhaustive search, and a serial online exhaustive search, and that there are differences among these search methods.

Here, an offline exhaustive search is a method of testing the passwords using data obtained by eavesdropping

communication, without connecting to the server. For example, when a random number c and r calculated by $r = h(c, pw)$ are transmitted through the communication channel and function $h()$ is public while only a password pw is secret, the attacker that eavesdropped on them can verify whether pw' is the correct password or not by calculating $r' = h(c, pw')$ using the password candidate pw' and checking whether $r = r'$ is valid. The number of passwords that can be tested is increasing year by year in proportion to increased computational capacity, and this is an extremely powerful method of attack since it is not limited by the server's setting.

As the length of keys that is sufficiently secure against offline exhaustive searches, the National Institute of Standards and Technology (NIST) of the USA recommends the use of more than 80 bits until 2010, more than 112 bits from 2011 to 2030, and more than 128 bits or more after 2031.^[3] These correspond to 14, 19, and 22 characters, respectively, when converted to the length of passwords consisting of randomly selected small and capital letters and numbers. In fact, based on this estimate, the file encryption software recommends the use of passwords with 20 characters or longer.^[4] On the other hand, the length of passwords that can be memorized by a human effortlessly is about 7 ± 2 characters,^[5] and this cannot withstand an offline exhaustive search.

In contrast, the parallel and serial online exhaustive searches are methods where, in the authentication protocol executed with the server, the guessed password is validated by checking whether it is acceptable or not. The serial online exhaustive search is a method of testing the passwords one by one for a single account, while the parallel online exhaustive search is a method where parallel searches are done for multiple accounts. In either method, the password cannot be tested unless one is connected to the server, and therefore, the risk against password exhaustive searches can be controlled regardless of increase of computational power, by limiting the number of passwords that can be tested during a certain period of time on the server.

This means that depending on what type of exhaustive search can be applied to a password handling method, the length of passwords that can be used securely varies. For the column of the resilience against password exhaustive searches in Table 1, the case where the offline exhaustive search can be applied is marked \times , the case where the parallel online exhaustive search can be applied is Δ , and the case where neither can be applied is \circ . The case where the stored information is leaked will be explained in subchapters 1.3 and 1.4. Even in the case where there is no information leakage, in the "conventional protocol using password only," the offline exhaustive search can be applied just by eavesdropping on the communication channel. Also in case of "PAKE" and "PKI server authentication + PW," parallel online exhaustive search can be executed on multiple accounts since anyone

Table 2. Examples of information leakage incidents from servers

Information leakage incidents	Outline of incident
Information leakage from Adobe Systems ^[6]	It was announced that there was possibility that about 2.9 million customer information was leaked due to illegal access (October 2013).
Information leakage from OCN ^[7]	It was announced that there was possibility that about 4 million OCN account information was leaked outside due to illegal access (July 2013).
Information leakage from Yahoo! Japan ^[8]	It was announced that there was high possibility that about 1.48 million user IDs and "secret information" for password resetting were leaked due to illegal access (May 2013).
Information leakage from Yahoo! USA ^[9]	About 400,000 user login authentication information was leaked outside due to cyber attack (July 2012).
Information leakage from Citigroup ^[10]	About 210,000 credit card customer information was leaked due to illegal access (Jun 2011), and the total financial damage by illegal use of the leaked card information was over 200 million yen. ^[11]
Information leakage from Sony PSN ^[12]	Large-scale personal information leakage occurred due to unauthorized invasion to Sony's PSN (Play Station Network, 77 million users) and Qriocity (April 2011). Due to this incident, Sony was ordered to pay a fine of about 35 million yen in the UK. ^[13]

can test the password. In cases of "PKI server authentication + PW + OTP," "PKI mutual authentication," or "LR-AKE," not even online exhaustive search can be applied since the correctness of the password cannot be tested online unless authentication information other than the password from the client is available.

1.3 Vulnerability against information leakage from the server

Generally, servers are carefully managed by specialist managers, and it has been thought that information leakage was not likely to occur. However, in recent years, incidents of information leakage from servers have occurred quite frequently, and it is becoming more difficult to assume that such information leakage does not occur. Table 2^{[6]-[13]} shows major information leakage incidents from servers in the past 2-3 years.

With the information leakage from the server, the problem is that large amount of information is leaked at one time and many users are subject to being exposed. The average estimated compensation per person calculated by the Japan Network Security Association for the first semester of FY 2012 was 57,710 yen.^[14]

For the effect on the password authentication method in the case where the information leakage occurs from the server, in the method categorized as the "PKI server authentication + PW" and "PKI server authentication + PW + OTP," the user's

password or the hash value (value to which the password is processed) is stored on the server. Therefore, if such values leak, the password can be identified by applying the offline exhaustive search. Moreover, if the identified password has been reused for other services, there may be subsequent exposure on services where the leaks have not occurred.

In the method categorized as “PKI server authentication + PW + OTP,” information to generate one-time passwords is also stored on the server, and if this information is leaked, the one-time password that the user has to enter can be known.

1.4 Vulnerability against information leak from the client

Figure 2 shows the number of incidents of information leakages that occurred through loss, misplacement, or theft of the devices or memory media. This figure is created from the statistical data from 2005 to 2011 published in the Japan Network Security Association’s “Report on the information security incidents.”^[15]

The number of leakage incidents declined steadily until about 2007, and this is thought to be due to the implementation of regulations against carrying out personal computers and portable media at companies and organizations to counter the information leakage incidents that occurred earlier. However, the effect slowed down after 2007, and the cases cannot be reduced to 300 or less per year. These figures reflect only the large-scale incidents that were covered by the news media, and the number is expected to increase if the small-scale incidents that did not make the news are included. Moreover, many more people are likely to carry small and highly functional devices such as smart phones and tablets in the near future, and the numbers of loss, misplacement, or theft of such devices are expected to increase proportionally.

The client device contains the information necessary for remote user authentication such as the encryption key that

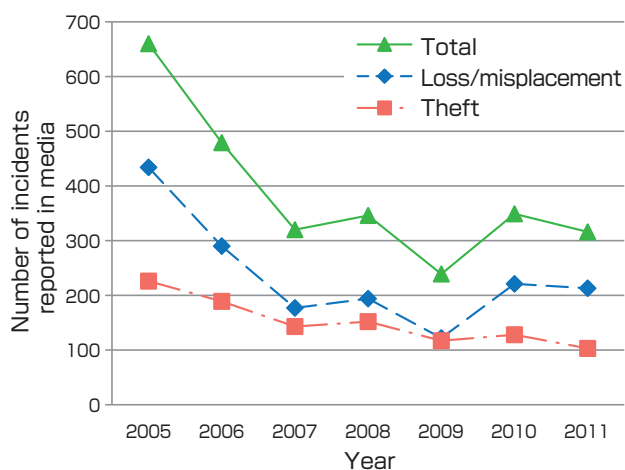

Fig. 2 Number of information leakage incidents from clients

was encrypted with password in the authentication method or the passwords stored on the device, and if such information leaks, impersonation of the user or identification of the user’s password becomes possible. In the method categorized as “PKI mutual authentication” in Table 1, the key for user authentication is stored in the client device, and this key is generally encrypted with a password. Therefore, if an attacker acquires the device, the password and key can be found by offline exhaustive search.

1.5 Vulnerability against phishing

In the methods categorized as “PKI server authentication + PW” and “PKI server authentication + PW + OTP” in Table 1, the encrypted communication channel is established between the user and the server, and then the password or one-time password entered by the user is transmitted to the server through this encrypted communication channel. The user authentication is done when the transmitted password or one-time password is decrypted and compared to the correct values in the server. Since the communication channel is encrypted, the password or OTP cannot be obtained even if eavesdropping occurs. However, the attacker may try to steal the information such as the user password by leading the user to a fake server made by the attacker. Various tactics may be used, for example, by sending spam mail that may claim: “Your passcode of your bank account has been leaked. Please change the password immediately from the following website.” In the method categorized as “PKI mutual authentication,” while the user’s password is not transmitted to the server, the information entered after authentication (for example, credit card number and personal information) may be stolen.

In the methods using these PKIs, there are mechanisms that warn the user when the user connects to a fake server, but these may not function effectively because a non-malicious server may use a self-signed public key certificate, the user may ignore the warning when led to a fake server, or there may be fake servers that have valid certificates (without warning) generated when a leaked CA’s signature key is abused. In contrast, in PAKE and LR-AKE, the password is not transmitted to the server, and the valid server does not have such a warning. Since the server authentication is conducted in the authentication protocol, the connection to the fake server is forcibly denied.

2 Research scenario to solve the problem

The scenario of this research is shown in Fig. 3. The goal is to devise and put into practice new methods that solve the problems of passwords shown in middle-left of the figure, and to provide this technology to society. The characteristic of this research scenario is that the practical application research is conducted only after thorough consideration of the problem solvability and the improvements of the

fundamental cryptographic theories for problem solving. This is because in a case where a fatal cryptanalytic method on the fundamental cryptographic technology is discovered after the deployment of the new technology, vast amount of cost and time will be needed to correct the basic principle and to change the method, since the problem cannot be solved with simple corrections such as patch applications. In fact, there are many examples where cryptanalytic methods were discovered for wireless LAN,^[16] electronic keys for automobiles,^[17] IC cards,^[18] and mobile phones after their deployments,^[19] and that have become major social problems.

The stages of the research scenario will be explained in the following subchapters.

2.1 Theoretical research for the problem solvability

To clarify at an early stage whether a certain social problem can be solved by science and technology is very important since this knowledge aids the decision on whether to pour the research resource into that topic, and this may in turn lead to the optimal assignment of resources. Fortunately, it is possible to theoretically clarify whether the required item can be solved for the problems related to cryptographic technology, and based on the problem solvability the main stage of the research can be continued smoothly.

In this research, the theoretical decision would be made on whether the problems described in subchapters 1.2 to 1.5 can be solved by cryptographic technology. If they are unsolvable problems, the reasons why they cannot be solved are clarified theoretically, and if they are solvable, the actual instantiations are presented. If it cannot be clarified whether a problem is solvable or unsolvable, it is raised to academic societies as an open problem and the cooperation of other researchers is sought.

2.2 Research for improvements in theoretical aspects

In the case where the problem solvability is theoretically not impossible, a specific solution will be presented, but

the initial solution will have room for improvements in computational complexity and security. Therefore, the theoretical improvements of the solution will be conducted over some time. Such improvements may be done by the original researchers, or may be done by other research groups. Also, such improvements in the information security field will be done against offense as well as defense, and the improvements from the offensive side plays a very important role. This is because if an attacker makes improvements to the attack method after the method is deployed to society or if the defender predicts possible new attack methods beforehand, the latter will dramatically reduce the cost of correction and effect on society.

2.3 Research for the practical application

A method for which no attack can be found and which has been theoretically improved advances a step closer to practical use. Research for practical use includes the followings:

- Research for additional functions needed in case of practical use,
- Research for implementation method,
- Research for coordinating with other application software.

The first is research to make the proposed method more usable or to enable multiple usages, and the second is research on how these will be implemented. The third is research on how to coordinate implemented methods with external software. The details and results of this research that was actually conducted will be described in the following chapter.

3 Inspection and result of the research scenario

In this chapter, research topics selected in order to realize the research goals according the aforementioned scenario, the reasons for selection, and the results will be explained.

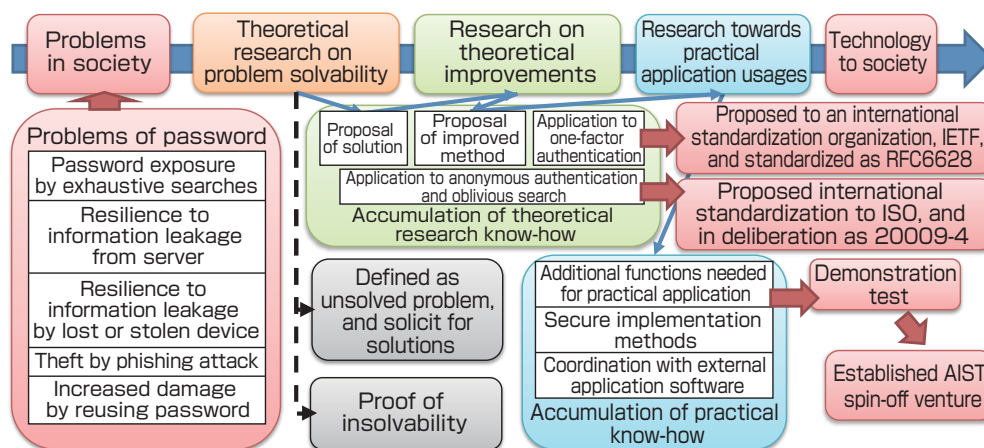

Fig. 3 Scenario of this research

3.1 Result of theoretical research on the problem solvability

When it is found that the aforementioned problem is solvable by the research at this stage, the limiting conditions required for the solution become apparent. The main limiting conditions are described below.

- [Limiting condition 1] Assuming that the stored information is leaked totally from the server in the one-factor authentication, where the user remembers only one short password, it is impossible to protect the user's password from offline exhaustive searches no matter how the cryptographic technologies are combined.

With this condition, it is clear that all the problems in subchapters 1.2 to 1.4 cannot be solved using the one-factor authentication where the user remembers only one short password. Therefore, we decided to focus the research topic on two-factor authentication where the information other than the password is stored on the client side. However, simply employing two factors in the authentication method does not lead to a solution of the problems. In fact, the previous "PKI server authentication + PW + OTP" method that has been widely used as the two-factor authentication is vulnerable to leakage from the server, and the "PKI mutual authentication" method, as a different two-factor authentication, is weak against the leakage of information stored on the client side. There has been no proposal or case study in the research community and the industry on how short passwords, the authentication information to be stored in the client device, and the cryptographic technology can be combined to solve the problems. This was also an academically challenging issue.

On the other hand, the following condition can be derived as the limit of two-factor authentication methods.

- [Limiting condition 2] Assuming that the stored information is leaked from both the server and the client at the same time in the two-factor authentication, where the user remembers one short password and stores information, it is impossible to protect the user's password from offline exhaustive searches no matter how the cryptographic technologies are combined.

Here, "the stored information is leaked ... at the same time" means that leakages of the stored information from both the server and the client occur in the same authentication transaction. However, this leaves room for problem solving in a case, for example, the server's stored information used in the n th authentication and the client's authentication information used in the $n+1$ th authentication are not used in the same authentication transaction. Therefore, the highest-level of security for which the solvability is not denied by this limiting condition is that the user's password is protected from offline exhaustive searches even if the

stored information is leaked from both the server and the client, unless the leakages occur at the same time. By the way, the parallel online password exhaustive searches are ineffective in two-factor authentication only when there is sufficient number of candidates of authentication information stored in the client device. This is because in the two-factor authentication, unless a large number of the authentication information stored on the client side can be obtained, the online password exhaustive search cannot be applied in parallel.

We had conducted the research by focusing on whether a composition that satisfies the highest-level of security for which the solvability of resilience against information leakage is not denied exists or not, and proposed a specific solution that satisfied the condition for the first time in the world. The main points of the technological composition include that, first, the independently selected secret information for each server is stored on the client side, and then, the verification data computed from the secret information stored on the client device and only one password remembered by the user are stored on each server as information to be used to authenticate the user. By doing this, it becomes difficult to retrieve the password from the verification data stored on the server. By automatically updating the information stored on the client side and the server side after the authentication is completed successfully, it also becomes difficult to find out the password even if the leakages occur from both the client and the server at different time slots. Moreover, we designed a cryptographic protocol where an attacker cannot narrow down the password candidates even if the attacker obtains the stored information and the messages that are exchanged through the communication channels.

We named this method Leakage-Resilient Authenticated Key Establishment (LR-AKE).^[20]

3.2 Research result of the improvements in the theoretical aspect

In this stage of the research, we have worked on how to reduce the computational costs of LR-AKE, how to strengthen security against much more sophisticated attacks, and how to prove the security of LR-AKE mathematically by showing the reduction to the computationally-hard problem. Also, we succeeded in improving the previous one-factor authentication and oblivious search methods by applying the knowledge accumulated through this research.

For computational costs, in the initially proposed method,^[20] the required cryptographic processing (specifically, about 720 times of multiple-precision multiplication with 1024-bits or more) was heavy on the client, and it was not easy to conduct such heavy cryptographic processing on the thin client devices such as the mobile phones used at the time. Therefore, we proposed a method where the number of

multiple-precision multiplication could be reduced to three times, and also proved that breaking the proposed method is equivalent to solving the mathematically hard problem.^[21]

For strengthened security against much more sophisticated attacks, we proposed a method where an attacker cannot retrieve the user's password and data distributed between the server and the client even if the attacker replaces authentication information stored on the client side into anything, and proved that to break the proposed method is equivalent to solving the mathematically hard problem.^[22] The authentication information stored on the client side may be stored on a portable medium for carrying, but this attack assumed a case where the portable medium is stolen, rewritten, and then returned to the original place.

By applying the knowledge of the cryptographic protocol designs accumulated through research at this stage, we also succeeded in improving the PAKE, the anonymous PAKE, and the oblivious search method. However, since these protocols use only one factor as secret information, the resilience to offline exhaustive searches using the information leaked from the server cannot be guaranteed. Yet, they achieve security against eavesdropping on the communication channel and impersonation attacks (identification of search word in the oblivious search method) with the least computational costs, and we succeeded in proving that to break the proposed methods is equivalent to solving the mathematically hard problems.^{[23]-[25]} Here, the anonymous password authentication protocol is a method to only verify that a user belongs to a certain group without making the server identify the individual user. This can be applied to the following usages:

- Anonymous whistleblowing from a member of an organization,
- Anonymous counseling service to a member (such as counseling for medical condition, bullying, or personal troubles),
- Formation of community for members with a certain attribute (such as women only),
- Anonymous communication channel restricted to the purpose of use.

The above method can also be used as an efficient core engine for conducting search while hiding the search word from the server by using the search word instead of the password, and for conducting matching while keeping each other's condition secret. The method of Reference [25] was proposed to the International Organization for Standardization (ISO), and the deliberation for standardization as 20009-4 (Anonymous entity authentication – Part 4: Mechanisms based on weak secrets) is in progress.^[26] For the method of Reference [23], the specification for application to a general Internet protocol, Internet Key Exchange version 2 (IKEv2) was proposed to the Internet Engineering Task Force (IETF), an

international standardization organization, and was approved and published as the international standard RFC6628.^[27] In an implementation version of the LR-AKE system, the methods of References [23] and [24] are used as the subprotocols to distribute the client's authentication information to users via the network by issuing one-time passwords to the users. The methods are contributing greatly to enhance the usability of user registration.

3.3 Research result towards practical use

In this subchapter, we explain the specific contents and results of the research mentioned in subchapter 2.3.

3.3.1 Research result of the additional functions needed in practical use

In order to realize both usability and security in LR-AKE, we devised several ways to maintain a high-level of security even if the user selects a short password. Specifically, even if an attacker obtains messages exchanged through the communication channel and data stored on either the server or the client side, the protocol is designed in a way that the offline and parallel online exhaustive searches of the password cannot be applied. Also, even if an attacker obtains the authentication information leaked from the client device and sequentially tests the password candidates one by one on the server, the stored authentication information is automatically updated when the regular user completes authentication successfully, and after that the leaked authentication information that the attacker obtained can no longer be used.

The attacker can test the password candidates until the stored authentication information is updated, but it is possible to lock the user's account after a fixed number of authentication failures. However, with a simple method such as the above, a low-level attacker who does not have the client's stored authentication information can disrupt the valid authentication process by locking the legitimate user's account by intentionally failing authentication, or by overloading the server with a large amount of authentication requests. Therefore, we devised and implemented a mechanism where in case such a low-level attacker connects, the authentication process is terminated without overloading the server, and in case of authentication failure, it is possible to determine whether an impersonator is testing without knowing the stored information, whether a password is being tested from a different device using the leaked stored information, or whether a legitimate user typed a wrong password.^[28] This enables the detection of attacks using the leaked information while preventing the illegal lockdown of a legitimate user account and the disruption of authentication server service by the attacker who has not obtained the stored authentication information.

Moreover, if all the password authentication methods are

replaced with LR-AKE, the user just needs to remember only one password even if the user uses several independent services. However, during a transition period, the user must memorize or store several passwords, used in other services, in addition to the LR-AKE password. Therefore, we considered and implemented a function, by using the characteristic of LR-AKE that makes it resilient against information leakage, whereby important information such as passwords and encryption keys used in other methods are placed in distributed storages after being computed with the LR-AKE server, the client and the LR-AKE password, and the original information cannot be restored unless the LR-AKE authentication is completed successfully.^[29] The information placed in distributed storages in LR-AKE cannot be restored from the information stored in either the server or the client side as in the case of LR-AKE password, and these information are automatically updated each time the LR-AKE authentication is successfully done.

However, by adding this distributed storage function, a new problem emerged. Our proposed method is resilient against leakage as mentioned earlier, but the stored original data cannot be retrieved if the stored information on either the server or the client side become unavailable. Also in LR-AKE, the information stored on the server and the client are updated, whenever authentication is successfully done, in order to maximize resilience against leakages. Therefore, in cases of malfunction of the server or loss of the client device, the original data in distributed storages in LR-AKE cannot be retrieved even if one of the nodes is restored to the previous state using the backup data. By using the multiple LR-AKE servers and multiple clients, the original data was made retrievable after node crashes while maintaining leakage resilience, and also the information stored on one LR-AKE client device was made retrievable from other LR-AKE client devices. Also in a case where the user mistakenly locked the account by entering wrong passwords several times surpassing the threshold number of failures, we implemented a mechanism to unlock the account from the user's effective LR-AKE account. We call such redundant configuration of the LR-AKE the cluster mode,^[30] in order to distinguish it from the single mode that is the configuration of one client device and one server.

If the cluster mode is used, in addition to placing the personal data in distributed storages in the LR-AKE, a group can be formed so that the same information is shared within the group without leaking the information to the server.^[31] Therefore, for example, computer administrators of a company can manage important information securely within the group, such as sharing the administrator's password for servers and devices. In such a case, the password that each user must remember can be a short one, and that password will not be known to the other group members or the server administrator.

3.3.2 Research result of the implementation method

Since the LR-AKE will be basically used in a situation where a high level of security is required, we also considered security measures during the implementation in addition to maintaining its high security level. These operations mainly followed the best practice for secure implementation, and did not yield results such as academic papers or patents for which novelty was demanded. However, the knowledge gained in these operations was greatly useful in advancing the research for cyber security of critical infrastructures and control systems in which we became involved later.

Also, some ambiguous parts of the specification became apparent only after we actually implemented it. As mentioned earlier, LR-AKE is equipped with the function to update the stored information after user's successful authentication in order to automatically invalidate the leaked authentication information, and the mechanism for determining whether the cause of authentication failure was a typing mistake by the legitimate user or whether the password was being tested using the stored information leaked from the client. Since these were assumed for cases where the protocol was completed normally, ambiguous parts remained for what would occur in a case where the communication was suddenly cut off. Therefore, we investigated a way to ensure recovery of communication at all times and to maintain the above functions and security level, even if the communication was cut off at any point in the protocol, and this was reflected in the details of the specifications and then implemented.

3.3.3 Research result of the coordination with other software applications

When precision of the implementation increased, the coordination with various application software became an issue. One method was to incorporate the LR-AKE as part of each software, but this method became problematic because it required a lot of workloads in which corrections were necessary at each update of LR-AKE in addition to the initial corrections to the software. Moreover, since the boundaries of responsibility were ambiguous, it became difficult to obtain cooperation of the application developers. Therefore, the Application Programming Interface (API), an interface to call up the LR-AKE function from the application software side, was defined, and an attempt was made to eliminate the correction in coordinating the software during the LR-AKE update. That is, the interface was not changed when the LR-AKE was updated or a new interface was added while the old one was left intact. Moreover, we investigated and implemented the coordination mechanism without correcting the program on the application side. Specifically, a one-time password is created on the LR-AKE client side and the server side after the LR-AKE authentication, the server uses the password registration protocol of the application, the one-time password is registered as the user password to be

used in the application, and finally the client uses the one-time password to obtain authentication using the password authentication protocol provided by the application. At the same time, the server authentication is done by delivering the information about the server to the client via a secure communication channel set up between the LR-AKE server and the LR-AKE client. With this coordination mechanism, the user can receive various services linked with LR-AKE just by performing the LR-AKE authentication, and the source code of the linked application does not have to be changed.

In fact, this mechanism was used in the demonstration test at AIST. In this test, the LR-AKE and the Virtual Private Network (VPN) that allows the authenticated users over external networks to be connected to the intra network were coordinated, and the users could use some services of the AIST network by performing the LR-AKE authentication. Of course, since the VPN software is a product of a different company, we could not change its source code. Therefore, we enabled the coordination without changing the VPN source code using the aforementioned mechanism. As the demonstration test, the system went into operation on March 13, 2010 to check that there were no problems, and from July 27, 2010 we asked participation of the Research Center for Information Security and the Tsukuba Advanced Computing Center to respond immediately in case any problem occurred, and had them use the system in place of the regular VPN connection. Since it was confirmed that there were no problems in the operation, we had prepared to have more people participate in 2011. However, the Tsukuba area was hit by the earthquake on March 11, 2011 and the servers of AIST Tsukuba including the LR-AKE server were shut down temporarily. Fortunately, the LR-AKE in the demonstration test was operated in the aforementioned cluster mode where the secondary server was set up in AIST Chugoku. So, we were able to continuously maintain the function of retrieving the data that were distributed in the LR-AKE cluster mode even after the coordination with VPN and the LR-AKE server at Tsukuba were shut down.

4 Conclusions

We discussed the basic theoretical researches and their practical application researches on the cryptographic construction that makes the exhaustive searches against the user's password impossible, even if the stored information is leaked from either the server or the client. Later, the practical application technology was offered as a commercial Software Development Kit (SDK) to call up the LR-AKE function from a software that requires user authentication and key management, as a commercial server, and as technical support, by setting up a spin-off AIST venture company. Moreover, part of the function was proposed to IETF and was published as an international standard RFC6628.

Currently, this technology is in an stage of being offered to society and being employed by innovators (innovative users according to the studies of innovation diffusion^[32]). In April 2013, we received the Encouragement Award of the Excellent New Technology/Product Award for small and medium-sized enterprises and the Special Award for industrial-academic-government cooperation sponsored by the Resona Group and Nikkan Kogyo Shimbun, and this was an opportunity to be known to some of industry.

However, from the fact that in the past it took about 20~30 years for the public key technology to be prevalent in society, it is expected that the same amount of time might be necessary for the prevalence of LR-AKE. Therefore, until LR-AKE is taken up by early adopters (users who are responsive to new items) or early majorities (users who take in new items earlier than average people), and reaches the critical mass of diffusion of about 16 % at which point the technology is said to start to spread rapidly, it is necessary to steadily accumulate achievements and to continue to work on activities to raise its awareness.

Also, we hope that this paper would be a reference for the practical use of research results and for offering such results to society.

References

- [1] M. Suzuki and M. Une: Seitai ninsho shisutemu no zeijakusei no bunseki to seitai kenchi gijutsu no kenkyu doko (Analysis of vulnerabilities of biometric authentication system and research trends in the biometric detection technology), *Kin'yu Kenkyu*, 28 (3), 69-106 (2009) (in Japanese).
- [2] National Police Agency: Heisei 23 nen chu no fusei akusesu koi no hasseijokyo-to no kohyo nitsuite (On the release of information for the occurrence of unauthorized access and others in 2011), <http://www.npa.go.jp/cyber/statics/h23/pdf040.pdf>, (2012) (in Japanese).
- [3] E. Barker, W. Barker, W. Burr, W. Polk and M. Smid: Recommendation for key management - Part 1: General (revision 3), *NIST Special Publication*, 800-57, (2012).
- [4] TrueCrypt Foundation: TrueCrypt Beginner's Tutorial Part 2, <http://www.truecrypt.org/docs/tutorial2>, accessed in August 2013.
- [5] G. A. Miller: The magical number seven, plus or minus two: Some limits on our capacity for processing information, *Psychological Review*, 63 (2), 81-97 (1956).
- [6] <http://headlines.yahoo.co.jp/hl?a=20131004-00000005-rbb-sci>, accessed in October 2013.
- [7] <http://www.ntt.com/release/monthNEWS/detail/20130724.html>, accessed in October 2013.
- [8] <http://itpro.nikkeibp.co.jp/article/NEWS/20130523/479201/>, accessed in October 2013.
- [9] <http://jp.reuters.com/article/technologyNews/idJPTJE86B02120120712>, accessed in October 2013.
- [10] <http://www.bloomberg.co.jp/news/123-LMJFD1A1I4H01.html>, accessed in October 2013.
- [11] <http://www.zaikei.co.jp/article/20110627/74852.html>, accessed in October 2013.

- [12] <http://www.nikkei.com/article/DGXZZO27529030X20C11A400000/>, accessed in October 2013.
- [13] <http://japanese.engadget.com/2013/01/24/psn-3500/>, accessed in October 2013.
- [14] Japan Network Security Association: 2012 Joho sekyuriti inshidento ni kansuru chosa hokokusho [Kamihanki sokuhoban] (Report on information security incidents in 2012 [Prompt report for the first semester]), <http://www.jnsa.org/result/incident/2012.html>, (2013) (in Japanese).
- [15] Japan Network Security Association: Joho sekyuriti inshidento ni kansuru chosa hokokusho (Report on information security incidents), <http://www.jnsa.org/result/2013.html>, (2009-2012) (in Japanese).
- [16] AIST: Musen LAN no sekyuriti ni kakawaru zeijakusei no hokoku ni kansuru kaisetsu (Explanation on the report of vulnerabilities of wireless LAN security), <https://www.rcis.aist.go.jp/TR/TN2009-01/wpa-compromise-summary.html>, (2009) (in Japanese).
- [17] K. Zetter: Researchers crack KeeLoq code for car keys, *WIRED*, <http://www.wired.com/threatlevel/2007/08/researchers-cra/>, (2007).
- [18] E. Phillips: Mifare crypto1 RFID completely broken, <http://hackaday.com/2008/01/01/24c3-mifare-crypto1-rfid-completely-broken/>, (2008).
- [19] H. Horesh: Technion team cracks GSM cellular phone encryption, <http://www.cs.technion.ac.il/~barkan/GSM-Media/HaaretzInternetEnglish.pdf>, (2003).
- [20] SH. Shin, K. Kobara and H. Imai: Leakage-resilient authenticated key establishment protocols, *ASIACRYPT 2003*, LNCS 2894, 155-172 (2003).
- [21] SH. Shin, K. Kobara and H. Imai: An efficient and leakage-resilient RSA-based authenticated key exchange protocol with tight security reduction, *IEICE Transactions*, E90-A (2), 474-490 (2007).
- [22] SH. Shin, K. Kobara and H. Imai: An RSA-based leakage-resilient authenticated key exchange protocol secure against replacement attacks, and its extensions, *IEICE Transactions*, E93-A (6), 1086-1101 (2010).
- [23] SH. Shin, K. Kobara and H. Imai: Secure PAKE/LR-AKE protocols against key-compromise impersonation attacks, *SITA 2008*, 965-970 (2008).
- [24] SH. Shin, K. Kobara and H. Imai: RSA-based password-authenticated key exchange, revisited, *IEICE Transactions*, E91-D (5), 1424-1438 (2008).
- [25] SH. Shin, K. Kobara and H. Imai: Anonymous password-authenticated key exchange: New construction and its extensions, *IEICE Transactions*, E93-A (1), 102-115 (2010).
- [26] ISO: Anonymous entity authentication - Part 4: Mechanisms based on weak secrets, http://www.iso.org/iso/home/store/catalogue_tc/catalogue_detail.htm?csnumber=64288, accessed in October 2013.
- [27] SH. Shin and K. Kobara: Efficient augmented password-only authentication and key exchange for IKEv2, *IETF, RFC 6628*, 1-20 (2012).
- [28] Y. Onda, SH. Shin, K. Kobara and H. Imai: How to distinguish on-line dictionary attacks and password mistyping in two-factor authentication, *ISITA2010*, 571-576 (2010).
- [29] SH. Shin, K. Kobara and H. Imai: Joho roei ni kenro na ninsho deta kanri shisutemu no gaiyo (shinguru modo) [Outline of leakage-resilient authentication and data management system (single mode)], *Computer Security Symposium 2007*, 2007 (10), 673-678 (2007) (in Japanese).
- [30] SH. Shin, K. Kobara and H. Imai: Joho roei ni kenro

na ninsho deta kanri shisutemu no gaiyo (kurasuta modo) [Outline of leakage-resilient authentication data management system (cluster mode)], *SITA 2007*, 790-795 (2007) (in Japanese).

- [31] SH. Shin, K. Kobara and H. Imai: Grupu kan deno fairu kyoyu o junan katsu anzen ni okonau tameno shin-hoshiki kento (On flexible and secure file sharing for group members), *Computer Security Symposium 2011*, 2011 (3), 803-808 (2011) (in Japanese).
- [32] E. M. Rogers: *Diffusion of Innovations*, 5th Edition, Free Press, New York (2003).

Authors

Kazukuni KOBARA

Received M.E. degree in computer science and system engineering from the Yamaguchi University in 1994. Joined the Institute of Industrial Science (IIS), The University of Tokyo in 1994. Research associate of IIS in 2000. Received his Ph.D. degree in engineering in 2003. Joined AIST in 2006. Engaged in the research of fundamental theory and its applications of information security technologies as the Leader of the Research Team for Security Fundamentals, Research Center for Information Security (RCIS), AIST. Principal Research Scientist in July 2006. From 2012, engages in the research of security technologies for control systems and critical infrastructures as the Leader of Control System Security Research Group, Research Institute for Secure Systems (RISEC), AIST. In this paper, engaged mainly in the research scenario and description of the practical application process.



SeongHan SHIN

Received Ph.D. degree in information science and technology from The University of Tokyo in 2005. Joined AIST in 2006. Engaged in the research of fundamental theory for authentication and cryptographic protocol as well as its applications in the Research Team for Security Fundamentals, Research Center for Information Security (RCIS), AIST. From 2012, engages in the research of security technologies for Internet service and international standardization in the Secure Service Research Group, Research Institute for Secure Systems (RISEC), AIST. In this paper, engaged mainly in description of the theoretical researches.



Discussions with Reviewers

1 Make the paper's title and abstract clearer and more structured

Comment (Toshihiro Matsui, Research Institute for Secure System, AIST)

The "next generation technology for ..." as in your title is often seen in proposals, but it merely indicates that something may become somewhat better by an improvement that cannot be described clearly. As the abstract says, "Here, next generation is ... to maintain a secure system even when a short password

is stolen either from a server or a client,” if you can show the content of the next generation, you should use a specific predicate to describe it. The proposed title is vague and can include all the papers for new authentication and key management that may appear in the future so that you cannot catch the reader’s attention. For *Synthesiology*, which is a technological journal that discusses the technological synthesis method for all specialties, I would like to see some indication that you are approaching a key idea of synthesis and methodology, rather than giving an introduction of a single technology. That is, from the title the reader should be able to image why such fundamental technology is necessary, and how it may change society and industry.

Answer (Kazukuni Kobara)

In the title, we changed the “next-generation authentication” to the more specific “secure password authentication,” and condensed the “key management infrastructures” and “LR-AKE” in the latter half into “their applications.”

2 Analysis of social and industrial problems and necessary technological development

Comment (Toshihiro Matsui)

The paper starts suddenly from comparison of the user authentication methods, and does not say which social problems this technological development is trying to solve. The definition of the problem and the significance of the research will become clear if you state in the beginning part of the paper the current situation of passwords, why they leak, what happens when they leak, why their protection is so difficult, and so forth. These are stated in order from subchapter 1.2 sequentially, but the order should be reversed.

Answer (Kazukuni Kobara)

We changed the beginning of chapter 1 to a description of the situation of passwords, and explained the way passwords are used and the causes of leakages. We also changed the structure of the paper to explaining difficulty of password protection from subchapter 1.2 to 1.5.

3 Characteristic as a Synthesiology paper

Comment (Toshihiro Matsui)

Reading through the paper, I understood that the characteristic of this research was not in making improvements based on feedbacks from the actual users, but in conducting R&D by preliminarily predicting all sorts of possible problems, taking measures, and conducting risk assessments in advance. In a technology like cyber security which emphasizes credibility for safety, it is not appropriate to take a common approach of offering a half-finished technology to society asking maturity and then making improvements. Therefore, it is necessary to extract and investigate all possible problems in advance and to take measures against them. I think that it is better to emphasize this point and describe it systematically.

Answer (Kazukuni Kobara)

As you pointed out, at the beginning of chapter 2 we described the characteristic of this research scenario, that is, “the importance to shift to practical application research only after conducting sufficient investigations and improvements on the security aspects of cryptographic technology that is the basis of

the proposed method in advance.”

4 One-factor PAKE

Comment (Toshihiro Matsui)

In subchapter 3.1, you write that the research will be limited to two-factor authentication because password leakages cannot be prevented with one-factor authentication. Yet in the middle of subchapter 3.2, you write that sufficient security might be obtained by improving the one-factor PAKE. As these two statements contradict, clarification is requested. After that, you also write about the search method hiding the search word as well as the development of an international standardization. If they are off the main topic, please remove these descriptions to avoid confusion.

Answer (SeongHan Shin, Kazukuni Kobara)

In order to avoid misunderstanding that two-factor authentication is unnecessary, we added in paragraph 4 of subchapter 3.2 that: PAKE and anonymous password authentication have security only against eavesdropping and impersonation; in oblivious search method, the search word is protected only against attacks over the network; and they are not resilient against leakage from the server.

Also, these subchapters present examples indicating that the technological knowledge accumulated in the theoretical improvement research can be applied to various applications. So, we added this explanation to the end of paragraph 1 as well as paragraph 4 of subchapter 3.2.

5 Explanation of offline exhaustive search and parallel online exhaustive search

Comment (Katsuhiko Sakaue, Information and Communication Infrastructure Division, AIST)

I understood that your proposed method is a powerful one where neither the offline nor parallel online exhaustive searches can be applied. However, since the readers from other fields may know only the familiar example of remote user authentication method, I don’t think that they can grasp what exactly are offline and parallel/serial online exhaustive searches only through the brief explanation given in the text. Because this is an important point that demonstrates superiority of the proposed method, I think you should add easy-to-understand explanations.

Answer (Kazukuni Kobara)

We added the explanations for offline and parallel/serial online exhaustive searches in subchapter 1.2.

6 Explanation of why it boils down to four problems

Comment (Katsuhiko Sakaue)

You give four problems of the current password authentication methods in subchapters 1.2~1.5, and at the beginning of chapter 2 you state that the goal of this research is to solve these problems fundamentally. However, the non-specialists cannot understand why it boils down to these four problems. Please add some clarifying explanations.

Answer (Kazukuni Kobara)

We added the statistical data on the ways of obtaining passwords in subchapter 1.1, and added explanations of how these ways are related to the four problems stated in subchapters 1.2~1.5.

Development of environmentally-friendly surface modification technology

— Practical realization of novel oleophobic coatings without relying on perfluorinated compounds and surface texturing —

Atsushi HOZUMI* and Chihiro URATA

[Translation from *Synthesiology*, Vol.7, No.3, p.190-198 (2014)]

Development of non-adhesive and dewetting solid surfaces has attracted much attention in a wide variety of industrial applications, because such surfaces can prevent staining, corrosion and clogging, and also permit control of droplet motion. In this paper, we introduce our strategy for R&D, including classification and analysis of previous work, and establishment of a guiding principle for R&D towards practical and rapid realization of our novel oleophobic coatings. Our R&D strategy successfully reduced the transition period from *Type 1* to *Type 2 Basic Research* and its practical realization. Furthermore, by means of seeds-needs matching between AIST and industrial companies, through PR activities and sample offers, we were able to establish our coating technology on a commercial scale within one year.

Keywords : Oleophobic treatment, dynamic dewettability, liquid-like surface, perfluorinated compounds, environmentally friendly

1 Introduction

The adherence of liquid droplets (of water or oil) to solid surface can cause corrosion, deterioration, degradation of appearance, or reduction of visibility, thereby significantly damaging the safety or reliability of devices or equipment. Therefore, the development of surface treatments that show excellent performance in removing droplets are being actively pursued. Droplet removal performance was conventionally evaluated only by the magnitude of the angle created by the tangent of a droplet to the solid surface, or the “contact angle” (in cases where water is used as a probe, it is called water droplet contact angle; it is also called the static contact angle, since it is an angle of an almost motionless state). The contact angle only reflects the physical properties of the outermost layer (about 1 nm) of the solid surface, and surfaces with large contact angle values are generally known as hydrophobic or oleophobic surfaces, while those with small values are called hydrophilic or oleophilic surfaces. In most studies up until now, droplet removal performance has been judged by the magnitude of the static contact angle. However, as can be seen in Fig. 1, in some cases the droplet adheres and will not move when the substrate is tilted 90° or more, even if the static contact angle is 150° or greater, depending on the surface conditions. The static contact angle and the droplet removal performance do not necessarily match.

Alternatively, other measurements that indicate droplet

removal performance include the dynamic contact angle (advancing/receding contact angles of the droplet, assuming the droplet can move on the solid surface, and the contact angle hysteresis that is the difference between the advancing/receding contact angles), and the critical angle (sliding angle) where a certain amount of droplet slides off the solid surface. The contact angle hysteresis and sliding angle reflect the droplet removal performance more accurately, and it is actually widely recognized that the droplet removal performance is superior when the contact angle hysteresis or the sliding angle is smaller. These observations suggest that the evaluation of droplet removal performance of solid surfaces should be done using the dynamic contact angle as the index, rather than the conventional static contact angle.

We have defined the droplet removal performance as “oleophobicity,” and have attempted to develop a method to confer excellent oleophobicity on various substrate surfaces. Therefore, we have reviewed past oleophobic treatments, particularly world research trends on oleophobic treatments, and constructed a research strategy by reviewing them from the new perspective of contact angle hysteresis. Although there were a few proposals of methods to control the contact angle hysteresis, they did not step outside the range of *Type 1 Basic Research*. In this paper, our research strategy, that aimed to give excellent and practical oleophobicity to substrate surfaces at low cost, will be discussed. If such surfaces can be put to practical use, the following industrial applications can be expected: prevention of staining;

Materials Research Institute for Sustainable Development, AIST 2266-98 Anagahora, Shimo-Shidami, Moriyama-ku, Nagoya 463-8560, Japan * E-mail: a.hozumi@aist.go.jp

Original manuscript received October 30, 2013, Revisions received January 10, 2014, Accepted January 14, 2014

improvement of anti-corrosive properties; flow control of MEMS (micro electro mechanical systems), NEMS (nano electro mechanical systems), and other biochips; prevention of ink jet nozzle clogging by residue caking; and others.

2 Issues of the conventional methods: What could be seen from conventional oleophobic treatments

Oleophobic surfaces that have been published so far can be roughly categorized into three groups: (1) smooth surfaces (liquid-like surfaces), (2) rough surfaces, and (3) rough wet surfaces. Figure 2 shows the types of oleophobic surfaces and their processing technologies.^[1] In this paper, the chronological sequence by which these surfaces were developed is discussed, and they will be referred to as the first-, second-, and third-generation oleophobic surfaces, respectively. Currently, the main subjects of *Type 1 Basic Research* are second- and third-generation oleophobic surfaces. First, the trend of the current oleophobic treatment

research will be outlined, and then the disadvantages of second- and third-generation surfaces, as well as the reason we returned to first-generation oleophobic surfaces are explained. By accurately understanding the advantages and disadvantages of conventional methods, and formulating the research policy accordingly, we were able to greatly shorten the time needed to shift from *Type 1 Basic Research* to practical realization.

2.1 Smooth surface (liquid-like surface) [first generation]

First-generation oleophobic treatments are simple methods, where an organic monomolecular film, terminated by low surface energy functional groups, is coated onto a smooth solid surface (Fig. 2a).^[2] Conventionally, to increase the magnitude of static contact angle (particularly oil) fluorinated molecules that are effective in decreasing the solid surface energy are used as starting materials. On the other hand, there are some reports of monomolecular film-coated surfaces showing excellent oleophobicity without using fluorinated compounds. For example, it was reported

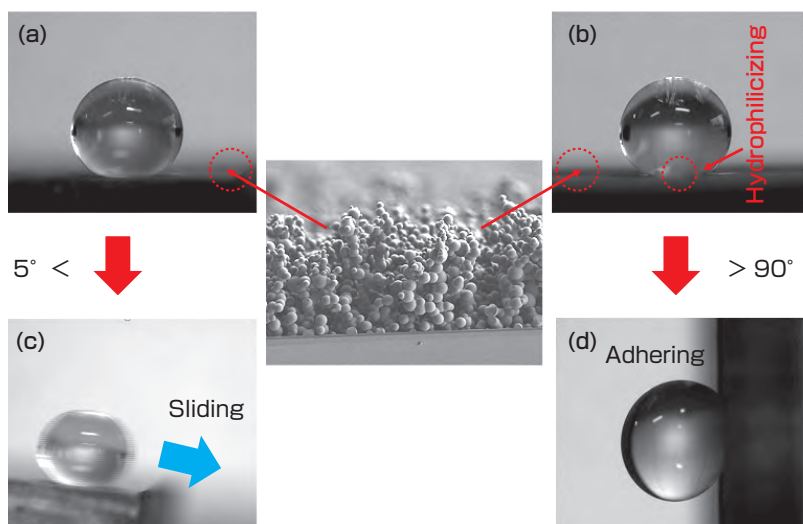

Fig. 1
 (a) State of static droplet on an ultra-hydrophilicized silicone substrate
 (b) State of static droplet on a partially hydrophilicized surface (a)
 (c) When (a) is tilted
 (d) When (b) is tilted

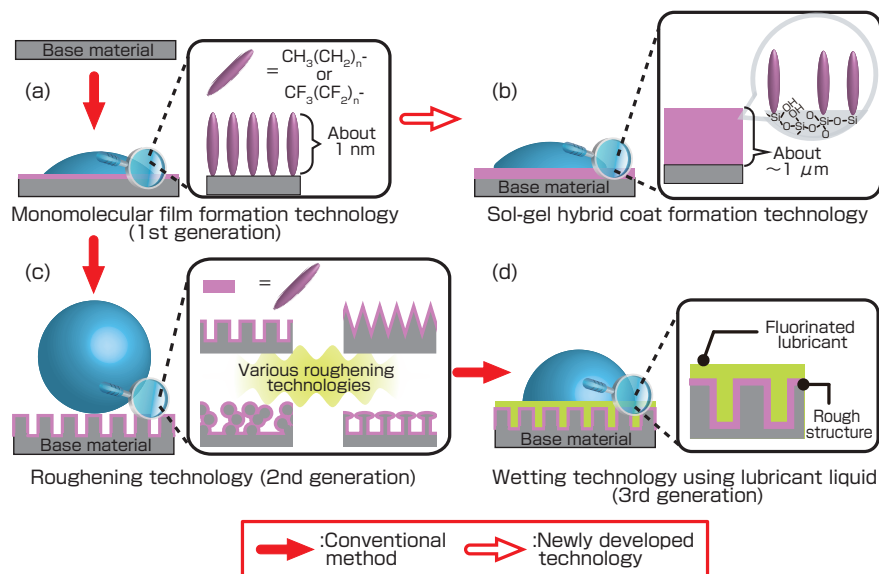

Fig. 2 Types of oleophobic surfaces and their fabrication methods
 (a) Oleophobic technology using a monomolecular film
 (b) Oleophobic technology developed in this research
 (c) Oleophobic technology using roughening technology
 (d) Oleophobic technology using lubricant liquid

in 1946 that a platinum substrate surface coated with a monomolecular film of a long-chain alcohol (20 carbon) showed excellent oleophobicity against *n*-hexadecane, a type of alkane, with a small static contact angle (about 40°).^[3] Although the principle was not clarified, in the late 1990s McCarthy *et al.* studied the correlation between the molecular density of alkyl group-terminated monomolecular films and oleophobicity, and experimentally demonstrated that the motility of the functional groups on a solid surface had a significant effect on the oleophobicity.^[4] They measured the changes in contact angle hysteresis of water and *n*-hexadecane as a function of the reaction time, and found that surfaces with an appropriate molecular density showed the best oleophobicity (Fig. 3). At this molecular density, a motile space is generated in the surface-fixed functional groups, and a “liquid-like” surface is formed. They also found excellent oleophobicity on monomolecular film-coated surfaces fabricated using bulky molecules with branched structures (terminated with alkyl groups). Droplets regardless of the type of probe liquids can slide off on such “liquid-like” surfaces.^{[4]-[6]} However, since such “liquid-like” surfaces have small contact angles against oil, it did not gain attention around the world as a truly oleophobic surface.

2.2 Rough surface [second generation]

For second-generation oleophobic surfaces, the objective is to increase the magnitude of contact angle (normally 150° or more) by simulating the rough, textured structure of a biological surface to reduce the contact area between the droplet and the solid surface. Therefore, (1) surface treatment by low surface energy molecule/film and (2) optimization of the rough structure are essential, and these are major research elements for second-generation oleophobic surface development (Fig. 2c). For example, for (1), it became apparent from first-generation research that surfaces terminated with -CF₃ groups showed the lowest surface energy (about 120° for the static contact angle of water). Therefore, long-chain perfluorinated compounds are used to most efficiently expose the group on the solid surface. For (2), taking inspiration from the microscopic structures of organisms, such as lotus leaves or springtails, the structure is optimized through calculation and simulation, and the

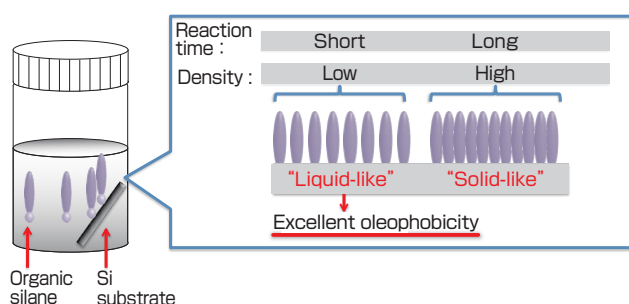

Fig. 3 Relationship between the surface functional group density and oleophobicity according to reaction time^[4]

surface treatment is done using lithography and/or other methods. In 2007, a paper in *Science* by Tuteja and Cohen *et al.* reported a surface from which oil droplets slide off like water droplets from a lotus leaf, made by optimizing the rough structure and by modifying the surface with perfluorinated compounds.^[7] Since this publication, second-generation research on oleophobic liquid treatments, as well as oleophobicity, has accelerated.^[8]

2.3 Rough wet surface [third generation]

Aizenberg *et al.* reported a new coating method that allowed improvement of oleophobicity without increasing the magnitude of contact angle, as observed in second-generation oleophobic treatments. They reported a surface treatment method with excellent oleophobicity called the slippery liquid-infused porous surfaces (SLIPS) in 2001 in *Nature*.^[9] There are microscopic grooves in the inner wall of the insect-trapping pitcher of the carnivorous plant *Nepenthes*, which are always covered with aqueous film. The oil on the legs of insects are repelled by this aqueous film, and the insect falls into the digestive fluid in the pitcher.^[10] The researchers looked at the interior wall of the insect-trapping pitcher and fabricated a surface that simulated the structure. Specifically, similar to the second-generation surface, a solid surface with a fluorine-treated rough structure was fabricated, and was wetted with a fluorine lubricant (Fig. 2d). The liquid film surface obtained did not exhibit a large contact angle, but showed excellent oleophobicity, where a mixture of blood and jam would slide off as well as water or oil. Since it is a liquid film, it also has self-repairing properties, whereby a defect disappears immediately, even if it occurs due to scarring. Currently, the research on SLIPS is gathering the most attention in the field of wettability research.^{[11]-[13]}

2.4 Disadvantages of the conventional oleophobic surfaces and treatment methods

The second- and third-generation artificial surfaces mentioned above show excellent oleophobicity, and their fabrication methods and optimized surfaces are interesting academically. However, all of these methods depend on rough structures and surface treatments with perfluorinated compounds, which we believed would hinder practical use.^[14] For example, rough structures have the following disadvantages:^[1] (1) mass production is difficult, because in many cases special conditions or equipment are needed for processing; (2) rough structures are fragile compared to smooth surfaces and impurities tend to deposit within the structure; (3) it is difficult to maintain transparency since the structures scatter visible light; and (4) droplets with a low surface energy, such as oil, wet and spread on rough surfaces (readily penetrate the interior of structure) and reduce the oleophobicity, or the oleophobicity decreases as the surface energy of the droplet decreases.

Perfluorinated compounds have the following problems: (1)

the price of the fluorite needed for manufacture fluctuates, (2) they are expensive because there are many steps to their synthesis, (3) they produce highly corrosive toxic fumes above a critical temperature, and (4) they tend to persist within the body or environment. Because of such problems, the long-chain perfluorinated compounds perfluorooctanoic acid (PFOA) and perfluorooctanesulfonic acid (PFOS) are regulated in their manufacturing and use, and there is an urgent demand for the development of alternative materials.

2.5 Analysis of the current situation

We concluded that because rough structures and perfluorinated compounds are essential for the fabrication of second- and third-generation oleophobic surfaces, they are limited in terms of technology, cost, and environmental impact, which inhibits their practical applications (Fig. 4). Therefore, we looked at first-generation smooth oleophobic surfaces, and focused on “how to realize surfaces where the functional groups behaved like liquid” and started the research. First, we looked at the fluidity and motility of polymers that are liquids at room temperature. Polydimethylsiloxane (PDMS) has a low glass-transition point (about $-120\text{ }^{\circ}\text{C}$) and is a liquid at room temperature. It is also known that PDMS fixed to a surface substrate retains the fluidity of the bulk phase. We surmised that because the glass-transition point decreases as the molecular weight is reduced, low molecular weight PDMS bound to a surface might exhibit “liquid-like” behavior. Therefore, PDMS polymers of different molecular weights were covalently fixed to a silicone substrate surface, and changes in static contact angle were investigated using various probe liquids (water, *n*-hexadecane, *n*-dodecane, and *n*-decane).^{[15][16]} It was found that the static contact angle decreased as the surface energy of the probe liquid decreased. Furthermore, it was found that the value of the static contact angle of each probe liquid remained constant, showing no dependence on the molecular weight of PDMS. This is thought to be because each PDMS surface had the same chemical

properties, despite the differences in molecular weight. On the other hand, the oleophobicity was highly dependent on the molecular weight of the PDMS (for the fluidity and motility of polymer chains). It was found that the contact angle hysteresis decreased for all probe liquids as the molecular weight decreased, and showed a corresponding decrease in sliding angle. In cases where the PDMS molecular weight was small, the contact angle hysteresis decreased against the alkanes as well as water. For example, the sliding angle decreased ($\sim 1^{\circ}$) against minute oil droplets ($3\ \mu\text{L}$ of *n*-decane), showing excellent oleophobicity. This value was much smaller than the sliding angle (5.3°) of *n*-decane ($5\ \mu\text{L}$) on the oleophobic surface, with a static contact angle of over 160° . In addition, since the alkane probe liquids were soluble in PDMS, a so-called “blended liquid-liquid interface” was formed between the oil and the PDMS chains. It is thought that the decreased contact angle hysteresis was caused by the interface acting as a plasticizing agent, causing the movement of the fixed polymer to become smooth due to swelling of the PDMS chains.

It was found that the surface that we created, originally based on the concept of the first-generation surface treatment technology, showed equivalent or better surface properties compared to the second- and third-generation oleophobic surfaces. However, in our experiments the treated solid surfaces were limited to silicone substrates, or metal substrates polished at nano-level, and there was a large technological barrier for applying this technology to practical base materials, such as plastic.

3 Research scenario for the realization of oleophobic surface

In order to realize the oleophobic treatment technology nurtured in *Type 1 Basic Research*, it was necessary to develop a surface treatment that satisfied the following four

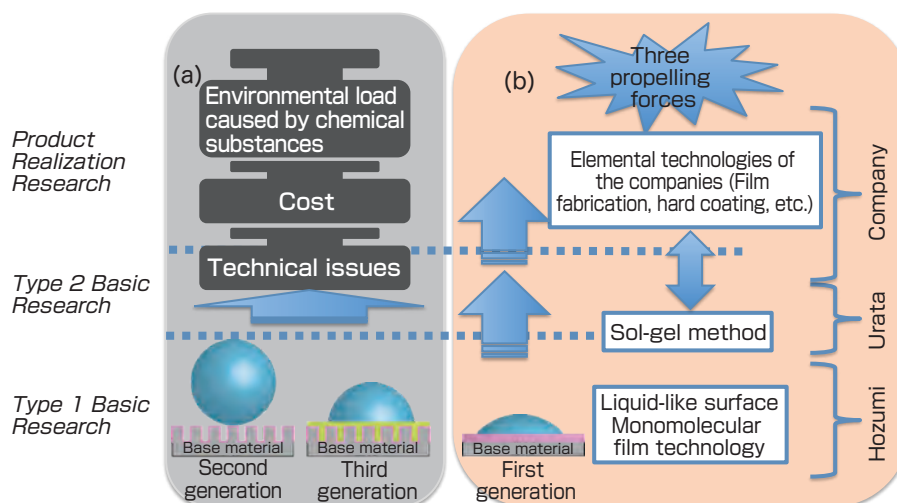

Fig. 4 Our research strategy

(a) Barriers to practical use if or when the conventional method is used. (b) Advantages of the newly developed method.

criteria: (1) should not depend on rough structure, (2) use as little perfluorinated compound as possible, (3) could be coated onto practical substrates, and (4) that coating could be applied using a simple method, such as painting. For first-generation methods, (3) and (4) were issues, and while we were looking at various surface treatment methods to solve them, Urata, who was involved in the sol-gel method research, joined our research group. The common factor in Hozumi's and Urata's research was a group of molecules called "organosilanes." Hozumi had been engaged in research to fabricate thin and monomolecular films as well as to control wettability using "organosilane" vapour for nearly 20 years.^{[17]-[21]} On the other hand, Urata was using "organosilane" to adjust the organic density of organic-inorganic hybrid materials. The sol-gel method is a process for synthesizing transparent inorganic solids via hydrolysis and condensation polymerization of molecules called alkoxy silanes, in liquid. When the organosilanes are added during the reaction mixture, an organic-inorganic hybrid material is formed, in which organic and inorganic phases are homogeneously mixed (Fig. 5b), and the organic concentration can be controlled easily by adjusting the solution composition.^[22] This method can be used for any base material, and is characterized by the fact that a film layer with excellent adhesion can be fabricated easily using dip or spin coating. After several discussions, we thought that the problems so far could be solved using the sol-gel method, and we decided on the research policy of "improving the motility of surface functional group of the layer obtained by controlling the concentration of organosilane in the reaction solution."

3.1 Sol-gel hybrid coating with excellent oleophobicity

We started the research by fabricating a hybrid layer from a mixture of organosilane and tetraalkoxysilane, and studying the relationship between the organosilane concentration and

oleophobicity. First, we used the octadecylsilane that has long alkyl chains and is known as a hydrophobic silane coupling agent. However, although we obtained hydrophobicity, it was found that total wet-spreading occurred for oil that had low surface energies, since the surface of the obtained layers had a rough structure at micrometer scale. Therefore, similar research was continued using molecules with different alkyl chain lengths, and we found that when organosilanes with chains shorter than a certain length were used, a hybrid layer with excellent oleophobicity was obtained, when formed at a certain concentration.^{[23]-[25]} This layer had excellent smoothness and transparency, and the surface could make various liquids, such as water, animal/vegetable oil, and alkane, slide without dependence on the surface energy of the droplets. In particular, it was found to have superior oleophobicity to monomolecular films or fluororesin fabricated by organosilane or perfluorinated compound alone (Fig. 6). This hybrid layer hardened at room temperature, and it not only had no limitations of base materials, and achieved relatively good adhesiveness without any special pretreatment, it also had an excellent function whereby fingerprints on the surface could be washed off easily with water. Such fingerprint removal performance is expected to be used in the surface treatments of smart phones and touch panel displays. Since it does not use perfluorinated compounds as raw materials, the environmental load is low and the cost can be greatly reduced. We also found that the lifespan of the reaction solution was about half a year. These were major advantages for practical use. However, more time was needed for determining the optimal solution composition, since for the sol-gel method, many complex factors such as chemical species, composition, and film forming conditions can influence the surface properties of the layer.

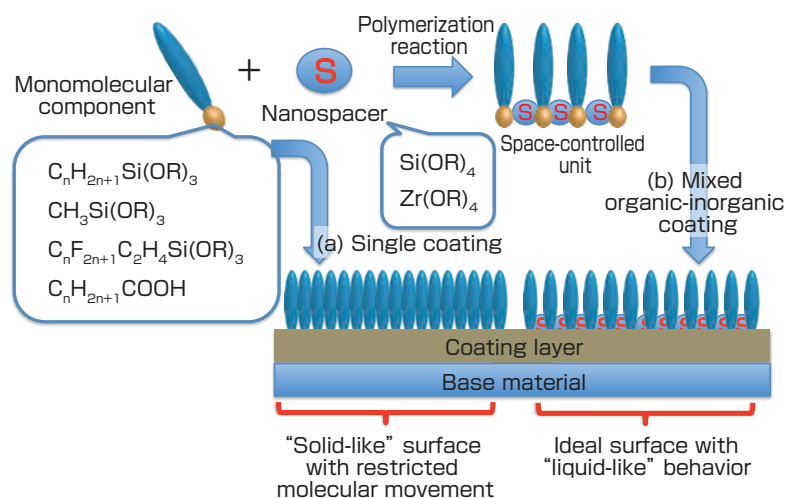

Fig. 5 Development policy for the oleophobic layer using the sol-gel method and variation of the chemical compositions

(a) Surface condition predicted from the monomolecular component only. (b) Surface condition predicted from the organic-inorganic coating.

3.2 Experimental verification of the hypothesis

Based on the above results, we formed the hypothesis that by controlling the chain length of the organosilane and the concentration of the reaction solution, the density of the alkyl groups that are exposed on the layer surface can be decreased, while their motility increases, which induces “liquid-like” properties on the layer surface, and this ultimately increases the oleophobicity. To verify this hypothesis experimentally, based on the findings obtained so far, we conducted similar research using perfluorinated silanes with perfluoroalkyl groups of different chain lengths (C_nF_{2n+1} : $n = 1-8$).^{[26][27]} Since the static contact angle is dominated by the surface energy, greater static contact angles were shown against water and oil when a long chain perfluorinated silane with an ($n=8$) perfluoroalkyl group was used. In contrast, it was found that the oleophobicity was not dependent on the chain length, and the same surface properties, equivalent to the hybrid layer fabricated using the long-chain perfluorinated silane, was shown even when a short-chain perfluorinated silane ($n \leq 4$) was used. It became clear that the oleophobicity was dominated not by the surface energy but by the motility of the surface functional groups. As mentioned previously, since the manufacture and use of the long-chain perfluorinated compounds will be regulated in the future, researchers around the world are trying to improve oleophobic performance using short-chain perfluorinated compounds ($n \leq 4$), but most research has ended in failure as oleophobic performance decreases as the chain shortens, because a liquid-like structure is not used. We were able to experimentally verify that sufficient oleophobicity could be obtained without using long-chain perfluorinated compounds if our method is used.

4 Effort toward practical use

Surface chemistry is a practical science. Surfaces and interfaces exist on all substances from the everyday products around us to industrial instruments. Reactions with other substances always start at the surface, and the surface-interface contributes to some sort of functional expression. Since the surface properties and the required surface properties of individual materials are varied, it can be readily imagined that there is a diverse field of applications and treatment methods.

We utilized the press release effectively to widely publicize our results to society, and surveyed which companies in which industrial fields would show interest in our potential technology. As imagined, we received requests for technical consultation and sample provision from a variety of industrial fields including automobiles, electrical machinery, cosmetics, printing, and foods. We were able to conclude an agreement for know-how provision and licensing with some companies with whom we found a win-win relationship for “seeds and needs (potential and demand).” Our technology withstood the companies’ rigorous screening, and the mass production level coating technology was established in a short period of one year from the first technical consultation. The reason that our developed technology progressed to a stage one step before practical use in such a short time is thought to be because the strategy for practical use was set up before starting the R&D, and that we reconsidered oleophobicity from the aspect of dynamic contact angles without being caught up in the conventional concept of static contact angles. Moreover, it was possible because of the enthusiasm of the researchers, advice from the innovation coordinator, as well as the support of the departments of AIST involved in intellectual property, contracts, public relations, and others, in addition to the film fabrication and hard coating technologies of the

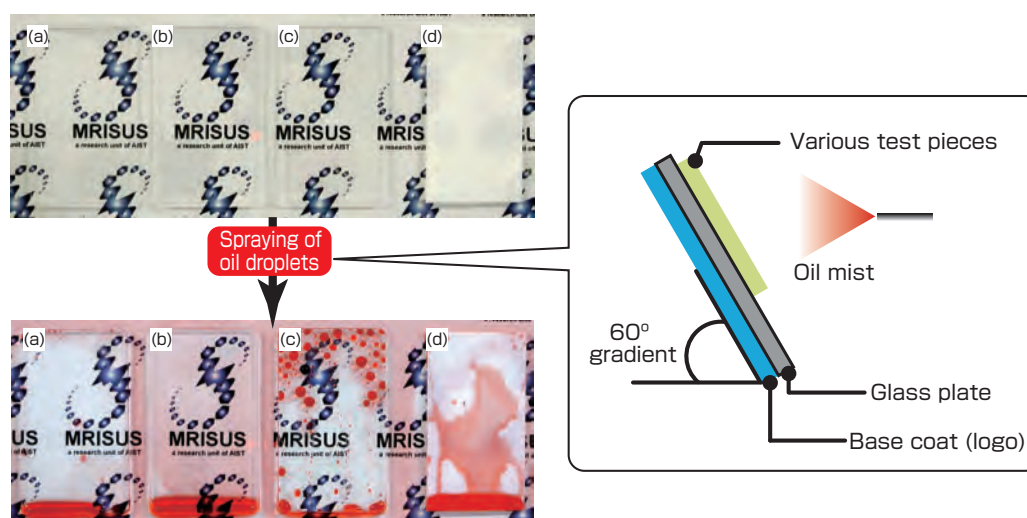

Fig. 6 Before and after spraying the various substrates with stained *n*-hexadecane

(a) Oleophobic coat developed in this research, (b) organic silane monomolecular film, (c) perfluorinated silane monomolecule, and (d) fluororesin (opaque). The oil droplets slid off the developed coat, while they remained adhered to other substrates.

partner companies. Currently, our industrial partners are working on marketing to commercialize the product.

5 Future issues and development

The transparent layer that we developed in this research shows excellent oleophobicity, but from the beginning, we were aware that there are weaknesses, such as insufficient film hardness and heat resistance, because 1) it is not heat treated and 2) there are many organic components. In fact, we received critical evaluations from many companies that the layer lacked durability. Based on the information and demand from the companies and objective self-evaluation of the current layer performance, we were able to determine a future policy for improvements. Currently, we are engaged in research to improve the layer performance.^{[28]-[30]} What is the technological development trend in the world, and what is the R&D that fulfills the corporate demand? We were also able to recognize from this R&D that information gathering and being sharp-eyed were important.

As mentioned earlier, it was experimentally verified that excellent oleophobicity was expressed by controlling the functional group density on the surface, but we have not clarified the principle based on scientific analysis. At one glance, the wettability research seems to be research of the surface, but in reality the interface formed by contact of the liquid and solid largely dominates the function. However, there are few analysis methods dedicated to interfaces, and this subject is hardly touched upon in the realm of wettability research. In the future, we hope to clarify the principle of this fascinating interface property by conducting joint research with specialists of analytical chemistry inside and outside AIST.

Also, artificial surfaces, such as the oleophobic layer, lose their function and are permanently impaired when the molecules that layer the surface are detached, the structure breaks down, or impurities deposit through damage, such as friction or wear. This is the definitive difference between artificial surfaces and biological surfaces that have tissue regeneration and self-repairing functions, and it is also the greatest factor inhibiting the practical use of oleophobic materials. In contrast, in the natural world, plant surfaces like the lotus leaf continue to secrete plant wax and maintain their surface functions, such as ultra hydrophobicity and self-cleaning. If it is possible to simulate such maintenance mechanisms and the continuous release of oleophobic molecules, as seen in those organisms, and to incorporate these functions to the layer, dramatic increases in the functional durability can be expected. In the future, we would like to work on the development of a novel functional layer that simulates the function-maintaining mechanism of organisms. Under the philosophy “one that controls the surface controls the material,” we plan to continue our

research toward the development and practical application of functional layers and surfaces through collaboration with the researchers inside and outside AIST, as well as with the administrative departments of AIST.

Acknowledgement

I express my gratitude to the joint researchers: Dr. Makoto Yagihashi of the Nagoya Municipal Industrial Research Institute; and Dr. Dalton Cheng and Dr. Benjamin Mashedor who were formerly post-doctorate researchers at AIST.

References

- [1] TS. Wong, T. Sun, L. Feng and J. Aizenberg (eds.): Interfacial materials with special wettability, *MRS Bull.*, 38 (5), 366-371 (2013).
- [2] A. Ulman: Formation and structure of self-assembled monolayers, *Chem. Rev.*, 96 (4), 1533-1554 (1996).
- [3] W. C. Bigelow, D. L. Pickett and W. A. Zisman: Oleophobic monolayers: I. Films adsorbed from solution in non-polar liquids, *J. Colloid Sci.*, 1 (6), 513-538 (1946).
- [4] A. Y. Fadeev and T. J. McCarthy: Trialkylsilane monolayers covalently attached to silicon surfaces: Wettability studies indicating that molecular topography contributes to contact angle hysteresis, *Langmuir*, 15 (11), 3759-3766 (1999).
- [5] A. Y. Fadeev and T. J. McCarthy: Binary monolayer mixtures: Modification of nanopores in silicon-supported tris(trimethylsiloxy)silyl monolayers, *Langmuir*, 15 (21), 7238-7243 (1999).
- [6] A. Y. Fadeev and T. J. McCarthy: Self-assembly is not the only reaction possible between alkyltrichlorosilanes and surfaces: Monomolecular and oligomeric covalently attached layers of dichloro- and trichloroalkylsilanes on silicon, *Langmuir*, 16 (18), 7268-7274 (2000).
- [7] A. Tuteja, W. Choi, M. Ma, J. M. Mabry, S. A. Mazzella, G. C. Rutledge, G. H. McKinley and R. E. Cohen: Designing superoleophobic surfaces, *Science*, 318 (5856), 1618-1622 (2007).
- [8] K. Liu, Y. Tian and L. Jiang: Bio-inspired superoleophobic and smart materials: Design, fabrication, and application, *Prog. Mater. Sci.*, 58 (4), 503-564 (2013).
- [9] TS. Wong, S. H. Kang, S. K. Y. Tang, E. J. Smythe, B. D. Hatton, A. Grinthal and J. Aizenberg: Bioinspired self-repairing slippery surfaces with pressure-stable omniphobicity, *Nature*, 477 (7365), 443-447 (2011).
- [10] H. F. Bohn and W. Federle: Insect aquaplaning: Nepenthes pitcher plants capture prey with the peristome, a fully wettable water-lubricated anisotropic surface, *Proc. Natl. Acad. Sci. USA*, 101 (39), 14138-14143 (2004).
- [11] X. Yao, Y. Hu, A. Grinthal, TS. Wong, L. Mahadevan and J. Aizenberg: Adaptive fluid-infused porous films with tunable transparency and wettability, *Nat. Mater.*, 12 (6), 529-534 (2013).
- [12] W. Ma, H. Wu, Y. Higaki, H. Otsuka and A. Takahara: A “non-sticky” superhydrophobic surface prepared by self-assembly of fluoroalkyl phosphonic acid on a hierarchically micro/nanostructured alumina gel film, *Chem. Commun.*, 48 (54), 6824-6826 (2012).
- [13] A. Grinthal and J. Aizenberg: Mobile interfaces: Liquids as a perfect structural material for multifunctional, antifouling surfaces, *Chem. Mater.*, 26 (1), 698-708 (2014). DOI: 10.1021/cm402364d.
- [14] Y. Zushi, J. N. Hogarth and S. Masunaga: Progress and

perspective of perfluorinated compound risk assessment and management in various countries and institutes, *Clean. Techn. Environ. Policy*, 14 (1), 9-20 (2012).

- [15] D. F. Cheng, C. Urata, M. Yagihashi and A. Hozumi: A statically oleophilic but dynamically oleophobic smooth nonperfluorinated surface, *Angew. Chem. Int. Ed.*, 51 (12), 2956-2959 (2012).
- [16] D. F. Cheng, C. Urata, B. Masheder and A. Hozumi: A physical approach to specifically improve the mobility of alkane liquid drops, *J. Am. Chem. Soc.*, 134 (24), 10191-10199 (2012).
- [17] A. Hozumi and O. Takai: Preparation of ultra water-repellent films by microwave plasma-enhanced CVD, *Thin Solid Films*, 303 (1-2), 222-225 (1997).
- [18] A. Hozumi, K. Ushiyama, H. Sugimura and O. Takai: Fluoroalkylsilane monolayers formed by chemical vapor surface modification on hydroxylated oxide surfaces, *Langmuir*, 15 (22), 7600-7604 (1999).
- [19] A. Hozumi, S. Asakura, A. Fuwa, N. Shirahata and T. Kameyama: Preparation of a well-defined amino-terminated self-assembled monolayer and copper microlines on a polyimide substrate covered with an oxide nanoskin, *Langmuir*, 21 (18), 8234-8242 (2005).
- [20] A. Hozumi, B. Kim and T. J. McCarthy: Hydrophobicity of perfluoroalkyl isocyanate monolayers on oxidized aluminum surfaces, *Langmuir*, 25 (12), 6834-6840 (2009).
- [21] A. Hozumi and T. J. McCarthy: Ultralyophobic oxidized aluminum surfaces exhibiting negligible contact angle hysteresis, *Langmuir*, 26 (4), 2567-2573 (2010).
- [22] M. Pagliaro, R. Ciriminna and G. Palmisano: Silica-based hybrid coatings, *J. Mater.Chem.*, 19 (20), 3116-3126 (2009).
- [23] C. Urata, D. F. Cheng, B. Masheder and A. Hozumi: Smooth, transparent and nonperfluorinated surfaces exhibiting unusual contact angle behavior toward organic liquids, *RSC Adv.*, 2 (26), 9805-9808 (2012).
- [24] C. Urata, B. Masheder, D. F. Cheng and A. Hozumi: How to reduce resistance to movement of alkane liquid drops across tilted surfaces without relying on surface roughening and perfluorination, *Langmuir*, 28 (51), 17681-17689 (2013).
- [25] C. Urata, B. Masheder, D. F. Cheng and A. Hozumi: A thermally stable, durable and temperature-dependent oleophobic surface of a polymethylsilsequioxane film, *Chem. Commun.*, 49 (32), 3318-3320 (2013).
- [26] J. Park, C. Urata, B. Masheder, D. F. Cheng and A. Hozumi: Long perfluoroalkyl chains are not required for dynamically oleophobic surfaces, *Green Chem.*, 15 (1), 100-104 (2013).
- [27] C. Urata, B. Masheder, D. F. Cheng and A. Hozumi: Unusual dynamic dewetting behavior of smooth perfluorinated hybrid films: Potential advantages over conventional textured and liquid infused perfluorinated surfaces, *Langmuir*, 29 (40), 12472-12482 (2013).
- [28] B. Masheder, C. Urata, D. F. Cheng and A. Hozumi: Novel transparent zirconium-based hybrid material with multilayered nanostructures: Studies of surface dewettability toward alkane liquids, *ACS Appl. Mater. Interfaces*, 5 (1), 154-163 (2013).
- [29] B. Masheder, C. Urata and A. Hozumi: Transparent and hard zirconia-based hybrid coatings with excellent dynamic/thermoreponsive oleophobicity, thermal durability, and hydrolytic stability, *ACS Appl. Mater. Interfaces*, 5 (16), 7899-7905 (2013).
- [30] D. F. Cheng, B. Masheder, C. Urata and A. Hozumi: Smooth perfluorinated surfaces with different chemical and physical natures: Their unusual dynamic dewetting behavior toward polar and nonpolar liquids, *Langmuir*, 29 (36), 11322-11329 (2013).

Authors

Atsushi HOZUMI

Completed the courses at the Graduate School of Engineering, Nagoya University in 1997. Doctor (Engineering). Joined the National Industrial Research Institute of Nagoya in 1999; Nanotechnology and Materials Strategy Planning Office, Nonferrous Metals Division, Manufacturing Industries Bureau, Ministry of Economy, Trade and Industry in 2006; Visiting Professor, University of Massachusetts Amherst from 2007; and Leader, Durable Materials Group, Materials Research Institute for Sustainable Development from 2010. In this research, was in charge of the fabrication of monomolecular and PDMS films and the evaluation of dynamic wettability.



Chihiro URATA

Completed the studies at the Department of Applied Chemistry, School of Advanced Science and Engineering, Waseda University. Doctor (Engineering). Joined AIST in 2011. Currently, researcher, Durable Materials Group, Materials Research Institute for Sustainable Development. In this research, was in charge of the development of sol-gel hybrid film.



Discussions with Reviewers

1 Practical application

Question and Comment (Toshimi Shimizu, AIST)

In this paper, various expressions are used for practical application. I understand that practical use technology is nearly established, but sometimes I get the impression that it is already accomplished. Please describe specifically and accurately how actually close the technology is to practical use, using a numerical value of physical properties or other ways.

Answer (Chihiro Urata)

As you indicated, this technology has not yet achieved practical use. I have heard from the partner companies of technological transfer, "We have a prospect for mass production, and we have given it a product code," but at this point, they are still working on marketing, and I think a bit more time is needed before commercialization. Therefore, I accurately described the current situation that "we have established the coating technology at mass production level."

2 Basic research to this point

Question and Comment (Hiroaki Tao, Research Institute for Environment Management Technology, AIST)

Only the papers after 2012 are cited as work by the authors. Was there *Type 1 Basic Research* related to this research or related elemental technology research before 2012? I think the basic research that you have built up made possible the achievement of near-practical use in a short period of one year from the start of the research. If this is the case, I recommend you briefly describe the basic research that was done prior to this research.

Answer (Atsushi Hozumi)

As you indicated, I have been engaging in basic research for nearly 20 years, including my student years, for the wettability control technology using thin films and monomolecular films. The findings and failures that I have experienced so far have been useful in the current research. I explained the outline of the past research and added the references to this paper.

3 Hydrophobicity/oleophobicity and hydrophilicity/hydrophobicity (oleophilicity)

Question and Comment (Hiroaki Tao)

Are you saying that the relationships of hydrophobicity/oleophobicity and hydrophilicity/hydrophobicity (oleophilicity) are different in the static and dynamic situations? I think it will facilitate understanding if you explain the relationships between the hydrophobicity/oleophobicity of the surface and the hydrophilicity/hydrophobicity of the molecules that are coated on the surface from the molecular structure perspective.

Answer (Atsushi Hozumi)

As you indicated, the situation is totally different in the static and dynamic cases. In the static condition, the contact angle of the alkyl group terminated surface against oil is 40° or less, and judging from the definition of conventional wettability (size of the contact angle), the surface will be oleophilic. However, our film has high alkyl group motility on the surface, and while it looks wet in appearance, dynamically, it is a readily sliding surface. We call such surface “liquid-like” because the molecules are in a mobile condition.

Following your instruction, I newly added Fig. 3 and text to explain the relationships between the hydrophobicity/oleophobicity of the surface and the hydrophilicity/hydrophobicity of the molecules that coat the surface from the molecular structure perspective. The mechanism of the reason for this unique dynamic wetting behavior is becoming clarified by spectrometry. Currently, I am writing a paper on this subject.

4 Elemental technologies of the companies and the examples of application

Question and Comment (Hiroaki Tao)

In practical application, what elemental technologies of the companies were added to the original technology of AIST? I think the value as a *Synthesiology* paper will increase by showing this point and, as much as you are allowed, the specific applications of this research.

Answer (Atsushi Hozumi)

The mass production technology was established, with the addition of the surface treatment technology developed by AIST to the film fabrication technology and hard coating technology of the partner companies. I heard that immediately after concluding the licensing agreement, the companies started marketing by distributing the prototypes to the affiliate companies. Personally, I think the technology can be applied to disposable films for automobile side mirrors to maintain visibility, and to coating which prevent fingerprints on touch panel displays.

MESSAGES FROM THE EDITORIAL BOARD

There has been a wide gap between science and society. The last three hundred years of the history of modern science indicates to us that many research results disappeared or took a long time to become useful to society. Due to the difficulties of bridging this gap, this stage has been recently called the valley of death or the nightmare stage^(Note 1). Rather than passively waiting, therefore, researchers and engineers who understand the potential of the research should actively try to bridge the gap.

To bridge the gap, technology integration^(i.e. Type 2 Basic Research – Note 2) of scientific findings for utilizing them in society, in addition to analytical research, has been one of the wheels of progress^(i.e. Full Research – Note 3). Traditional journals, have been collecting much analytical type knowledge that is factual knowledge and establishing many scientific disciplines^(i.e. Type 1 Basic Research – Note 4). Technology integration research activities, on the other hand, have been kept as personal know-how. They have not been formalized as universal knowledge of what ought to be done.

As there must be common theories, principles, and practices in the methodologies of technology integration, we regard it as basic research. This is the reason why we have decided to publish “*Synthesiology*”, a new academic journal. *Synthesiology* is a coined word combining “synthesis” and “ology”. Synthesis which has its origin in Greek means integration. Ology is a suffix attached to scientific disciplines.

Each paper in this journal will present scenarios selected for their societal value, identify elemental knowledge and/or technologies to be integrated, and describe the procedures and processes to achieve this goal. Through the publishing of papers in this journal, researchers and engineers can enhance the transformation of scientific outputs into the societal prosperity and make technical contributions to sustainable development. Efforts such as this will serve to increase the significance of research activities to society.

We look forward to your active contributions of papers on technology integration to the journal.

Addendum to Synthesiology-English edition,

“*Synthesiology-English edition*” is a translated version of “*Synthesiology*”, which is published quarterly, ISSN 1882-6229, by AIST.

Papers or articles published in “Synthesiology-English edition” appear approximately four months after the publication of the original “Synthesiology”. Those published in Japanese are translated into English, so the views expressed in translated versions are exclusively those of the Japanese authors and editors. The Japanese authors are generally consulted regarding the translation of their papers, but are not responsible for the published English version.

Papers or articles in the “Synthesiology” originally submitted in English are also reproduced just as they were published in “Synthesiology”. Some papers or articles in “Synthesiology” are not translated due to the authors’ or editors’ judgement.

Synthesiology Editorial Board
(written in January, 2008)

Note 1 : The period was named “nightmare stage” by Hiroyuki Yoshikawa, the then President of AIST, and historical scientist Joseph Hatvany. The “valley of death” was used by Vernon Ehlers in 1998 when he was Vice Chairman of US Congress, Science and Technology Committee. Lewis Branscomb, Professor emeritus of Harvard University, called this gap as “Darwinian sea” where natural selection takes place.

Note 2 : *Type 2 Basic Research*

This is a research type where various known and new knowledge is combined and integrated in order to achieve the specific goal that has social value. It also includes research activities that develop common theories or principles in technology integration.

Note 3 : *Full Research*

This is a research type where the theme is placed within the scenario toward the future society, and where framework is developed in which researchers from wide range of research fields can participate in studying actual issues. This research is done continuously and concurrently from *Type 1 Basic Research*^(Note 4) to *Product Realization Research*^(Note 5), centered by *Type 2 Basic Research*^(Note 2).

Note 4 : *Type 1 Basic Research*

This is an analytical research type where unknown phenomena are analyzed, by observation, experimentation, and theoretical calculation, to establish universal principles and theories.

Note 5 : *Product Realization Research*

This is a research where the results and knowledge from *Type 1 Basic Research* and *Type 2 Basic Research* are applied to embody use of a new technology in the society.

Editorial Policy

Synthesiology Editorial Board

Objective of the journal

The objective of *Synthesiology* is to publish papers that address the integration of scientific knowledge or how to combine individual elemental technologies and scientific findings to enable the utilization in society of research and development efforts. The authors of the papers are researchers and engineers, and the papers are documents that describe, using “scientific words”, the process and the product of research which tries to introduce the results of research to society. In conventional academic journals, papers describe scientific findings and technological results as facts (i.e. factual knowledge), but in *Synthesiology*, papers are the description of “the knowledge of what ought to be done” to make use of the findings and results for society. Our aim is to establish methodology for utilizing scientific research result and to seek general principles for this activity by accumulating this knowledge in a journal form. Also, we hope that the readers of *Synthesiology* will obtain ways and directions to transfer their research results to society.

Content of paper

The content of the research paper should be the description of the result and the process of research and development aimed to be delivered to society. The paper should state the goal of research, and what values the goal will create for society (Items 1 and 2, described in the Table). Then, the process (the scenario) of how to select the elemental technologies, necessary to achieve the goal, how to integrate them, should be described. There should also be a description of what new elemental technologies are required to solve a certain social issue, and how these technologies are selected and integrated (Item 3). We expect that the contents will reveal specific knowledge only available to researchers actually involved in the research. That is, rather than describing the combination of elemental technologies as consequences, the description should include the reasons why the elemental technologies are selected, and the reasons why new methods are introduced (Item 4). For example, the reasons may be: because the manufacturing method in the laboratory was insufficient for industrial application; applicability was not broad enough to stimulate sufficient user demand rather than improved accuracy; or because there are limits due to current regulations. The academic details of the individual elemental technology should be provided by citing published papers, and only the important points can be described. There should be description of how these elemental technologies

are related to each other, what are the problems that must be resolved in the integration process, and how they are solved (Item 5). Finally, there should be descriptions of how closely the goals are achieved by the products and the results obtained in research and development, and what subjects are left to be accomplished in the future (Item 6).

Subject of research and development

Since the journal aims to seek methodology for utilizing the products of research and development, there are no limitations on the field of research and development. Rather, the aim is to discover general principles regardless of field, by gathering papers on wide-ranging fields of science and technology. Therefore, it is necessary for authors to offer description that can be understood by researchers who are not specialists, but the content should be of sufficient quality that is acceptable to fellow researchers.

Research and development are not limited to those areas for which the products have already been introduced into society, but research and development conducted for the purpose of future delivery to society should also be included.

For innovations that have been introduced to society, commercial success is not a requirement. Notwithstanding there should be descriptions of the process of how the technologies are integrated taking into account the introduction to society, rather than describing merely the practical realization process.

Peer review

There shall be a peer review process for *Synthesiology*, as in other conventional academic journals. However, peer review process of *Synthesiology* is different from other journals. While conventional academic journals emphasize evidential matters such as correctness of proof or the reproducibility of results, this journal emphasizes the rationality of integration of elemental technologies, the clarity of criteria for selecting elemental technologies, and overall efficacy and adequacy (peer review criteria is described in the Table).

In general, the quality of papers published in academic journals is determined by a peer review process. The peer review of this journal evaluates whether the process and rationale necessary for introducing the product of research and development to society are described sufficiently well.

In other words, the role of the peer reviewers is to see whether the facts necessary to be known to understand the process of introducing the research finding to society are written out; peer reviewers will judge the adequacy of the description of what readers want to know as reader representatives.

In ordinary academic journals, peer reviewers are anonymous for reasons of fairness and the process is kept secret. That is because fairness is considered important in maintaining the quality in established academic journals that describe factual knowledge. On the other hand, the format, content, manner of text, and criteria have not been established for papers that describe the knowledge of “what ought to be done.” Therefore, the peer review process for this journal will not be kept secret but will be open. Important discussions pertaining to the content of a paper, may arise in the process of exchanges with the peer reviewers and they will also be published. Moreover, the vision or desires of the author that cannot be included in the main text will be presented in the exchanges. The quality of the journal will be guaranteed by making the peer review process transparent and by disclosing the review process that leads to publication.

Disclosure of the peer review process is expected to indicate what points authors should focus upon when they contribute to this journal. The names of peer reviewers will be published since the papers are completed by the joint effort of the authors and reviewers in the establishment of the new paper format for *Synthesiology*.

References

As mentioned before, the description of individual elemental technology should be presented as citation of papers published in other academic journals. Also, for elemental technologies that are comprehensively combined, papers that describe advantages and disadvantages of each elemental technology can be used as references. After many papers are accumulated through this journal, authors are recommended to cite papers published in this journal that present similar procedure about the selection of elemental technologies and the introduction to society. This will contribute in establishing a general principle of methodology.

Types of articles published

Synthesiology should be composed of general overviews such as opening statements, research papers, and editorials. The Editorial Board, in principle, should commission overviews. Research papers are description of content and the process of research and development conducted by the researchers themselves, and will be published after the peer review process is complete. Editorials are expository articles for science and technology that aim to increase utilization by society, and can be any content that will be useful to readers of *Synthesiology*. Overviews and editorials will be examined by the Editorial Board as to whether their content is suitable for the journal. Entries of research papers and editorials are accepted from Japan and overseas. Manuscripts may be written in Japanese or English.

Required items and peer review criteria (January 2008)

	Item	Requirement	Peer Review Criteria
1	Research goal	Describe research goal (“product” or researcher’s vision).	Research goal is described clearly.
2	Relationship of research goal and the society	Describe relationship of research goal and the society, or its value for the society.	Relationship of research goal and the society is rationally described.
3	Scenario	Describe the scenario or hypothesis to achieve research goal with “scientific words”.	Scenario or hypothesis is rationally described.
4	Selection of elemental technology(ies)	Describe the elemental technology(ies) selected to achieve the research goal. Also describe why the particular elemental technology(ies) was/were selected.	Elemental technology(ies) is/are clearly described. Reason for selecting the elemental technology(ies) is rationally described.
5	Relationship and integration of elemental technologies	Describe how the selected elemental technologies are related to each other, and how the research goal was achieved by composing and integrating the elements, with “scientific words”.	Mutual relationship and integration of elemental technologies are rationally described with “scientific words”.
6	Evaluation of result and future development	Provide self-evaluation on the degree of achievement of research goal. Indicate future research development based on the presented research.	Degree of achievement of research goal and future research direction are objectively and rationally described.
7	Originality	Do not describe the same content published previously in other research papers.	There is no description of the same content published in other research papers.

Instructions for Authors

“Synthesiology” Editorial Board
Established December 26, 2007
Revised June 18, 2008
Revised October 24, 2008
Revised March 23, 2009
Revised August 5, 2010
Revised February 16, 2012
Revised April 17, 2013
Revised May 9, 2014

1 Types of articles submitted and their explanations

The articles of *Synthesiology* include the following types:

- Research papers, commentaries, roundtable talks, and readers' forums

Of these, the submitted manuscripts of research papers and commentaries undergo review processes before publication. The roundtable talks are organized, prepared, and published by the Editorial Board. The readers' forums carry writings submitted by the readers, and the articles are published after the Editorial Board reviews and approves. All articles must be written so they can be readily understood by the readers from diverse research fields and technological backgrounds. The explanations of the article types are as follows.

① Research papers

A research paper rationally describes the concept and the design of R&D (this is called the scenario), whose objective is to utilize the research results in society, as well as the processes and the research results, based on the author's experiences and analyses of the R&D that was actually conducted. Although the paper requires the author's originality for its scenario and the selection and integration of elemental technologies, whether the research result has been (or is being) already implemented in society at that time is not a requirement for the submission. The submitted manuscript is reviewed by several reviewers, and the author completes the final draft based on the discussions with the reviewers. Views may be exchanged between the reviewers and authors through direct contact (including telephone conversations, e-mails, and others), if the Editorial Board considers such exchange necessary.

② Commentaries

Commentaries describe the thoughts, statements, or trends and analyses on how to utilize or spread the results of R&D to society. Although the originality of the statements is not required, the commentaries should not be the same or similar to any articles published in the past. The submitted manuscripts will be reviewed by the Editorial Board. The authors will be contacted if corrections or revisions are necessary, and the authors complete the final draft based on the Board members' comments.

③ Roundtable talks

Roundtable talks are articles of the discussions or interviews

that are organized by the Editorial Board. The manuscripts are written from the transcripts of statements and discussions of the roundtable participants. Supplementary comments may be added after the roundtable talks, if necessary.

④ Readers' forums

The readers' forums include the readers' comments or thoughts on the articles published in *Synthesiology*, or articles containing information useful to the readers in line with the intent of the journal. The forum articles may be in free format, with 1,200 Japanese characters or less. The Editorial Board will decide whether the articles will be published.

2 Qualification of contributors

There are no limitations regarding author affiliation or discipline as long as the content of the submitted article meets the editorial policy of *Synthesiology*, except authorship should be clearly stated. (It should be clearly stated that all authors have made essential contributions to the paper.)

3 Manuscripts

3.1 General

3.1.1 Articles may be submitted in Japanese or English.

Accepted articles will be published in *Synthesiology* (ISSN 1882-6229) in the language they were submitted. All articles will also be published in *Synthesiology - English edition* (ISSN 1883-0978). The English edition will be distributed throughout the world approximately four months after the original *Synthesiology* issue is published. Articles written in English will be published in English in both the original *Synthesiology* as well as the English edition. Authors who write articles for *Synthesiology* in Japanese will be asked to provide English translations for the English edition of the journal within 2 months after the original edition is published.

3.1.2 Research papers should comply with the structure and format stated below, and editorials should also comply with the same structure and format except subtitles and abstracts are unnecessary.

3.1.3 Research papers should only be original papers (new literary work).

3.1.4 Research papers should comply with various guidelines of

research ethics

3.2 Structure

3.2.1 The manuscript should include a title (including subtitle), abstract, the name(s) of author(s), institution/contact, main text, and keywords (about 5 words).

3.2.2 Title, abstract, name of author(s), keywords, and institution/contact shall be provided in Japanese and English.

3.2.3 The manuscript shall be prepared using word processors or similar devices, and printed on A4-size portrait (vertical) sheets of paper. The length of the manuscript shall be, about 6 printed pages including figures, tables, and photographs.

3.2.4 Research papers and editorials shall have front covers and the category of the articles (research paper or editorial) shall be stated clearly on the cover sheets.

3.2.5 The title should be about 10-20 Japanese characters (5-10 English words), and readily understandable for a diverse readership background. Research papers shall have subtitles of about 15-25 Japanese characters (7-15 English words) to help recognition by specialists.

3.2.6 The abstract should include the thoughts behind the integration of technological elements and the reason for their selection as well as the scenario for utilizing the research results in society.

3.2.7 The abstract should be 300 Japanese characters or less (125 English words). The Japanese abstract may be omitted in the English edition.

3.2.8 The main text should be about 9,000 Japanese characters (3,400 English words).

3.2.9 The article submitted should be accompanied by profiles of all authors, of about 200 Japanese characters (75 English words) for each author. The essential contribution of each author to the paper should also be included. Confirm that all persons who have made essential contributions to the paper are included.

3.2.10 Discussion with reviewers regarding the research paper content shall be done openly with names of reviewers disclosed, and the Editorial Board will edit the highlights of the review process to about 3,000 Japanese characters (1,200 English words) or a maximum of 2 pages. The edited discussion will be attached to the main body of the paper as part of the article.

3.2.11 If there are reprinted figures, graphs or citations from other papers, prior permission for citation must be obtained and should be clearly stated in the paper, and the sources should be listed in the reference list. A copy of the permission should be sent to the Publishing Secretariat. All verbatim quotations should be placed in quotation marks or marked clearly within the paper.

3.3 Format

3.3.1 The headings for chapters should be 1, 2, 3..., for subchapters, 1.1, 1.2, 1.3..., for sections, 1.1.1, 1.1.2, 1.1.3, for subsections, 1.1.1.1, 1.1.1.2, 1.1.1.3.

3.3.2 The chapters, subchapters, and sections should be enumerated. There should be one line space before each paragraph.

3.3.3 Figures, tables, and photographs should be enumerated. They should each have a title and an explanation (about 20-40 Japanese characters or 10-20 English words), and their positions in the text should be clearly indicated.

3.3.4 For figures, image files (resolution 350 dpi or higher) should be submitted. In principle, the final print will be in black and white.

3.3.5 For photographs, image files (resolution 350 dpi or higher) should be submitted. In principle, the final print will be in black and white.

3.3.6 References should be listed in order of citation in the main text.

Journal – [No.] Author(s): Title of article, *Title of journal* (italic), Volume(Issue), Starting page-Ending page (Year of publication).

Book – [No.] Author(s): *Title of book* (italic), Starting page-Ending page, Publisher, Place of Publication (Year of publication).

Website – [No.] Author(s) name (updating year): Title of a web page, Name of a website (The name of a website is possible to be omitted when it is the same as an author name), URL, Access date.

4 Submission

One printed copy or electronic file (Word file) of manuscript with a checklist attached should be submitted to the following address:

Synthesiology Editorial Board
c/o Website and Publication Office, Public Relations
Department, National Institute of Advanced Industrial
Science and Technology(AIST)
Tsukuba Central 2 , 1-1-1 Umezono, Tsukuba 305-8568
E-mail: synthesiology-ml@aist.go.jp
The submitted article will not be returned.

5 Proofreading

Proofreading by author(s) of articles after typesetting is complete will be done once. In principle, only correction of printing errors are allowed in the proofreading stage.

6 Responsibility

The author(s) will be solely responsible for the content of the contributed article.

7 Copyright

The copyright of the articles published in “*Synthesiology*” and “*Synthesiology English edition*” shall belong to the National Institute of Advanced Industrial Science and Technology(AIST).

Inquiries:

Synthesiology Editorial Board
c/o Website and Publication Office, Public Relations
Department, National Institute of Advanced Industrial
Science and Technology(AIST)
Tel: +81-29-862-6217 Fax: +81-29-862-6212
E-mail: synthesiology-ml@aist.go.jp

Letter from the editor

Have you noticed? Starting from this issue, there is an introductory article at the beginning of the journal called the “Highlights of the Papers” by the Editorial Board. This is a new attempt to encourage more people to read and submit papers to *Synthesiology*. We hope to arouse interest in this journal by introducing the various efforts to deepen research and to contribute to society as methodologies. We are planning not only placement of this article on and links to our website but also to ask placements of this introductory page in other academic journals .

There is something I became aware of when we were creating the introductory text. It is the role of the “Discussion

with Reviewers” that characterizes this journal. Even if specialties differ, people engage in various discussions on the universality that can be learned from the papers. With some articles, you may be able to gain better understanding if you read this introductory part before the main text, so please make use of it.

In creating the highlights, the board members along with the reviewers thought hard using the “trial” of the “Letter from the Editor” in the previous issue as a base, but I think there is room for improvement. Please send your straightforward opinion to the Editorial Board to help us create easy-to-understand and attractive introductions.

(Shigeko TOGASHI, Senior Editor)

Synthesiology - English edition Vol. 7 No. 3, Dec. 2014

Edited by *Synthesiology* Editorial Board

Published by National Institute of Advanced Industrial Science and Technology (AIST)

Edited by *Synthesiology* Editorial Board

Published by National Institute of Advanced Industrial Science and Technology (AIST)

Synthesiology Editorial Board

Editor in Chief: T. KANAYAMA

Senior Executive Editor: M. SETO, N. YUMOTO

Executive Editors: C. KURIMOTO, T. SHIMIZU, M. TANAKA, S. TOGASHI, H. HATORI, M. AKAMATSU, F. UEDA (New Energy and Industrial Technology Development Organization), A. OKADA (Sumitomo Chemical Company, Limited), N. KOBAYASHI (Waseda University), T. MAENO (Keio University), M. YAMAZAKI, M. TAKAHASHI

Editors: H. AKOH, S. ABE, S. ICHIMURA (Nagoya University), K. UEDA (Hyogo Prefectural Institute of Technology), A. ONO, A. KAGEYAMA, S. KANEMARU, T. KUBO, N. KOHTAKE (Keio University), K. SAKAUE, H. TAO, M. TAKESHITA (New Energy and Industrial Technology Development Organization), H. TATEISHI, H. TAYA, (J-Space Inc.), K. CHIBA, E. TSUKUDA, H. NAKASHIMA (Future University Hakodate), S. NIKI, Y. HASEGAWA, Y. BABA (The University of Tokyo), T. MATSUI, Y. MITSUISHI, N. MURAYAMA, M. MOCHIMARU, Y. YANO, A. YABE, H. YOSHIKAWA (Japan Science and Technology Agency)

Publishing Secretariat: Publication Office, Public Relations Department, AIST

Contact: *Synthesiology* Editorial Board

c/o Website and Publication Office, Public Relations Department, AIST

Tsukuba Central 2, 1-1-1 Umezono, Tsukuba 305-8568, Japan

Tel: +81-29-862-6217 Fax: +81-29-862-6212

E-mail: synthesiology-ml@aist.go.jp

URL: http://www.aist.go.jp/aist_e/research_results/publications/synthesiology_e

*Reproduction in whole or in part without written permission is prohibited.



Highlights of the Papers in *Synthesiology*

Research papers

Development of a stable growth factor suitable for radioprotection

—*Drug development-aimed R&D at a basic research institute*—

T. IMAMURA

Development of a protein array for autoantibody profiling of blood

—*Comprehensive disease diagnosis using the body's defense system*—

Y. KAWAKAMI and N. GOSHIMA

Technological development of internal heat-integrated distillation column (HIDiC)

—*Substantive research of application to a bench plant of bioethanol distillation*—

K. KATAOKA and H. NODA

Secure password authentication schemes and their applications

—*How to achieve security with short passwords*—

K. KOBARA and S.H. SHIN

Development of environmentally-friendly surface modification technology

—*Practical realization of novel oleophobic coatings without relying on perfluorinated compounds and surface texturing*—

A. HOZUMI and C. URATA

Messages from the editorial board

Editorial policy

Instructions for authors

“*Synthesiology-English edition*” is a translated version of “*Synthesiology*,” which is published quarterly, ISSN 1882-6229, by AIST. Papers or articles published in “*Synthesiology-English edition*” appear approximately four months after the publication of the original “*Synthesiology*.”

