

Natural Gas Renewable  
Energy

# **NEW ENERGY TECHNOLOGY FOR SOCIETY**

**—Approach by Field Test and Evaluation—**



*National Institute of  
Advanced Industrial Science  
and Technology*

**AIST**

# NEW ENERGY TECHNOLOGY FOR SOCIETY

## —Approach by Field Test and Evaluation—

### Field Test Study in Energy

#### The trend in the development of energy technology

One of the most important issues for sustainable development of human society is finding the solutions to the environment/energy problems such as global warming and finiteness of fossil fuel. There are great expectations for the development and dissemination of new technologies in energy field.

In response, technological developments are being promoted even further toward the following goals:

- lowering carbon content in fuel, carbon dioxide recovery and storage, carbon dioxide emissions reduction by using other energies such as nuclear power
- introduction and diffusion of renewable energy
- energy saving by improving energy conversion efficiency and usage efficiency in each field.

AIST, with these goals in mind, is vigorously doing research and development of renewable energy technologies such as clean fuel/hydrogen technology, photovoltaic, wind power, geothermal, biomass technologies, high-efficiency energy conversion technology such as fuel cells, and technologies that support the above in a cross-sectoral manner such as energy storage/transport technologies and power electronics technology.

Moreover, in order to achieve drastic reduction goals of carbon dioxide emissions by 2050, it is necessary to realize a totally new energy system which incorporates every new technology in a massive scale. AIST is doing research that aims to construct a

new system which functions without strain while drastically reducing carbon dioxide emissions.

On the next page is shown an image of an energy system of the future.

#### Significance of field test study of energy technology

To disseminate new energy technology in society, it is necessary not only to simply develop each elemental technology in the laboratory but also to do field tests and evaluation studies in the actual conditions of usage. The objectives are verification of practicality and reliability of elemental technologies, development of control/operational technology in order to match the changing power output with demand, and total optimization of the system.

Especially with actual usage of renewable energy, it differs extensively according to regions, and the usage time patterns and demand rate of various energies such as electricity/heat also differ depending on regions and users. It is indispensable to do field tests not only to gain these actual data but also to form a system which can provide energy at a high reliability.

In addition, in energy technology development, even during field tests and after being introduced to the market, new knowledge and needs are fed back from actual sites of use, and they often accelerate improvement of performance.

In this manner, field test and evaluation study in the energy field can be said to be an important bridge to tie research development and society bi-directionally.



#### Field test study of energy technology at AIST

From all the above viewpoints, we, at AIST, are doing field tests and evaluation studies of various technologies at a relatively small scale. In this brochure, we present field tests and evaluation studies of the following; (1) a cogeneration system including heat storage in cold districts, (2) an air-conditioning system using geothermal energy, (3) a biofuel application technology, (4) a photovoltaic generation system.

With (1), a system which improves usage efficiency by storing/emitting part of the heat of micro gas turbine is being tested at one of the buildings at Sapporo City University. With (2), we are doing a field test study of a home air-conditioning system which combines underground heat source of constant temperature with a heat pump in Tsukuba, Ibaraki. With (3), we are doing road-running tests of diesel engine cars using such fuels as synthetic fuel and biodiesel fuel. With (4), we are doing evaluation of long-term reliability of a photovoltaic generation system linked with the electrical system

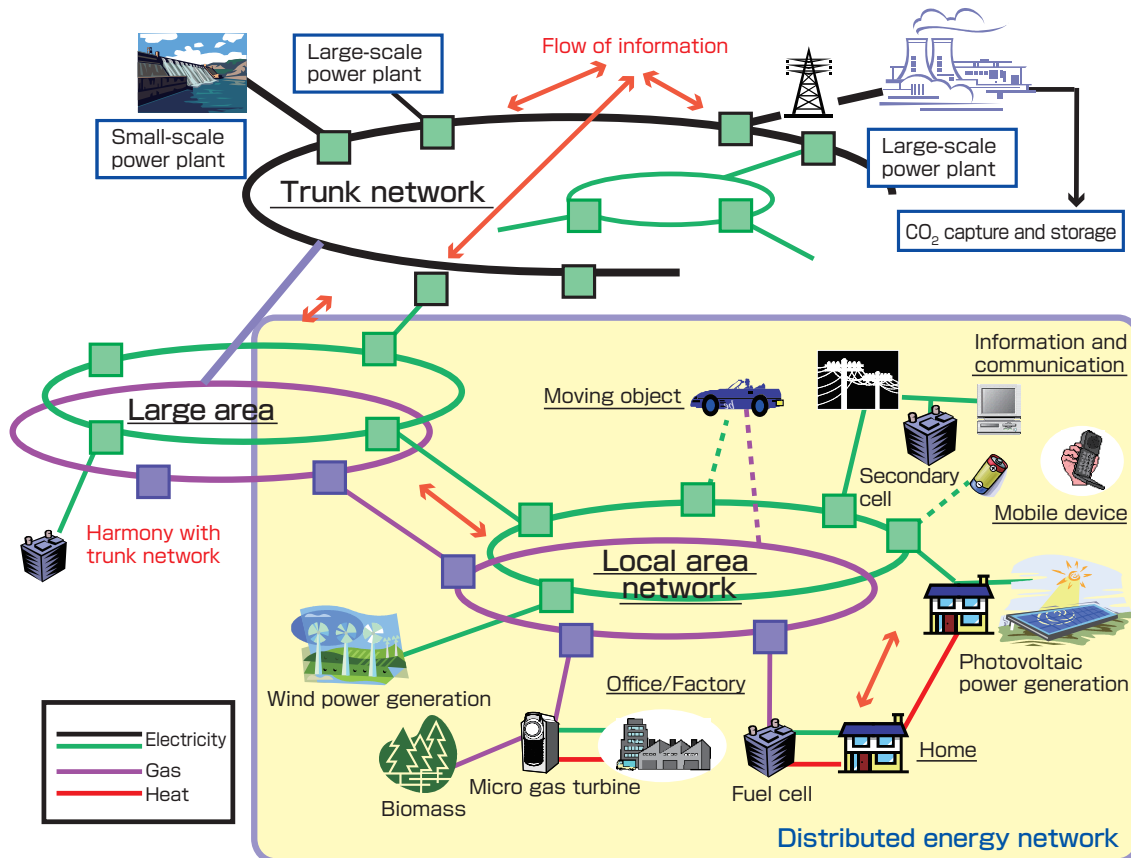

**Image of future energy system**

Much of the distributed energy sources such as photovoltaic generation, wind power generation and fuel cells form networks near their demands and harmoniously tie up with other trunk networks.

within the AIST compound.

All of these are research done by constructing a system with elemental technologies developed at AIST, and collaborating closely with experimental sites of local governments and/or private sectors. Although there are differences of degree, they all have shown good results related to energy saving and carbon dioxide emissions reduction, and are being ongoingly used after the study period. For details, please read the article on each case.

Furthermore, although they are not mentioned in this brochure, we are also doing the following studies.

- field test study of fuel cell network in the home (*AIST TODAY*, 7( 6) , 36(2007))

- field test study of energy saving by flow resistance reduction of air-conditioning circulating water of the main building of Sapporo City Hall (AIST press release, May 28, 2007)

- field test study of energy system of central section of AIST Tsukuba (the 4<sup>th</sup> Symposium on Dispersed Energy, Dec. 2007)

Other than these, we are presently doing basic research on a system that uses intermittent photovoltaic and wind power generation combined effectively with secondary battery, hydrogen production/storage technologies, and electrical systems, and plan to move on to doing research on a field level.

We would like to release as much data and results as possible that have been achieved

from the field test studies, and would like to contribute to the introduction and dissemination of devices and systems of even higher performances that are to follow.

For the introduction and dissemination of new energy technology, installation guidance policies of national and local government levels are important and absolutely necessary along with technological development efforts for performance improvement and cost reduction. With technological development and administrative measures working together, the realization of a new energy system for prevention of global warming is anticipated in the near future.

Research Coordinator  
**Yoshiro Owadano**

# Field Test Study of Cogeneration Using Supercooled Thermal Energy Storage

## Issues with cogeneration

To set a fireplace as part of a relaxing environment is not uncommon these days in Japan. If one lights a fire in a fireplace or irori (Japanese style sunken fireplace), one can not only cook and be heated, but can also gain soft lighting. A device by which one can use various types of energy simultaneously such as heat, light, electricity and motion is a cogeneration system.

The advantage of cogeneration is that, compared to using heat or electricity only, the fuel usage efficiency can be increased. However, there is a big problem of whether all recovered heat can be effectively used. This is because; (1) compared to light and electricity, the amount of supplied heat tends to be excessive, (2) the demand varies according to season and period of time, and (3) the time period of demand is frequently different from those of light and electricity.

## Outline of field test study

With cogeneration, the above-mentioned issue (1) can be resolved by applying it to cold places and facilities like hotels that have large thermal demands. To solve issue (2), optimal energy management in response to demand and supply is required. To solve issue (3), energy storage, especially thermal

energy storage is important.

We are presently doing a field test study to solve the issues (2) and (3) with the city of Sapporo from 2005. We have set up a system in the new building at Art Park Campus of Sapporo City University (a four story building of gross floor area of 4,157 m<sup>2</sup> with 14 classrooms). As shown in Fig. 1, electricity and heat generated by a micro-gas turbine (MGT) cogeneration system are provided as part of the hot water supply demand and heating/electricity demand.

One of the characteristics of this system is that it uses a mechanism original of AIST which uses supercooling phenomenon of phase change material (PCM) in the thermal energy storage device which stores exhaust heat of MGT temporarily.

## Sweet tasting storage material and supercooling

Sugar alcohol such as xylitol and erythritol is used much in improving teeth health and in dieting. As the PCM of this system, D-threitol, one of such sugar alcohol is used. The reason for its usage is that its melting point (87 °C) is appropriate for hot water supply, it is stable and safe, and that it is thought to be inexpensive when mass-produced. D-threitol, as shown in Fig. 2, is white crystal at room temperature

and turns into transparent viscous fluid at high temperature, and absorbs/discharges thermal energy of 250 kJ/kg during melting/solidification; so therefore, it can store large quantity of heat in small volume if it is used in the temperature range around melting point.

When the melt of D-threitol is cooled, it does not start to solidify at the melting point and is supercooled in the liquid phase, and it only starts to solidify at temperatures 20~60 °C lower than the melting point and recovers its temperature to the melting point with heat of solidification. If this characteristic is fully used, heat of solidification can be stored at temperatures lower than the melting point, and by starting crystallization on demand, thermal energy at high temperatures close to the melting point can be extracted.

D-threitol has been named as a possible PCM from the past, but it has not been put to practical use because of the inability to resolve the problem of large supercooling. By using the double-tank supercooling resolution method developed at AIST as shown in Fig. 3, D-threitol can be used as not only PCM but also as a functional thermal energy storage material with supercooled storage advantages.

## Heat storage characteristic

Operational conditions of the thermal

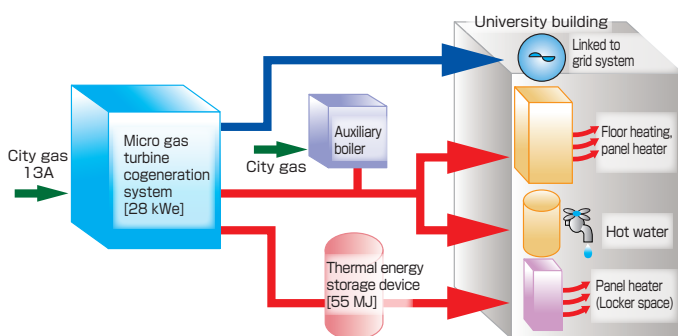

Fig. 1 Structural element of experimental system and flow of energy

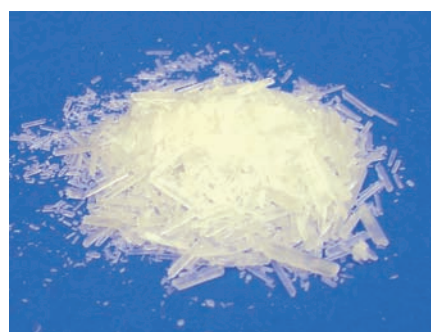

Fig. 2 D-threitol used as phase change material

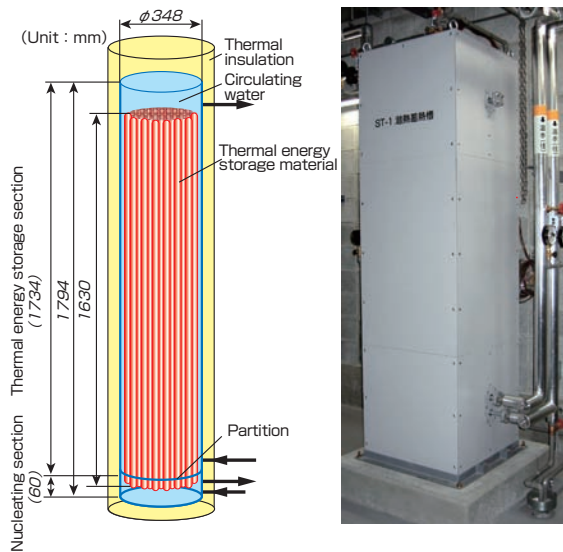

Fig. 3 Configuration of thermal energy storage tank and outward appearance of device  
Phase change material is filled with 96 long thin capsules (red).

energy storage device differ according to the temperature and demand of the day it is operated; however, Figs. 4, 5 show an operational example in November. From 8:00 to 18:00, heat recovered from exhaust gas of MGT is used for hot water supply and heating within the building. At the same time, part of the heat is supplied to the thermal energy storage device and locker space, and melting of the PCM and heating is done simultaneously (thermal input is shown by negative thermal output in Fig. 4).

From 18:00 to 19:00 after MGT is stopped, heat is supplied to the panel heaters from the thermal energy storage device as the first stage of heat release. In this heat release process, the PCM is supercooled and left in the liquid phase until the next morning.

From 4:00 to 5:00 of the next morning, crystal nuclei are formed in the bottom parts of the PCM capsules by water circulation to the nucleating section at the bottom part of the thermal energy storage tank in Fig. 3, the crystals grow upward, D-threitol within each capsule starts to solidify, and the temperature recovers to near the melting point. Then from 6:00 to just before 8:00, heat is supplied to panel heaters from the thermal energy storage

device as the second stage of heat release.

By using supercooling of the PCM in this manner, heat is released efficiently twice a day, in the morning and in the afternoon, and thermal loss from the thermal energy storage device to the surrounding environment is suppressed during the nighttime when heating is unnecessary. Thus, as shown in Fig. 5, 90 % of the thermal energy at high temperatures kept at the end of heat storage operation can be used for heating.

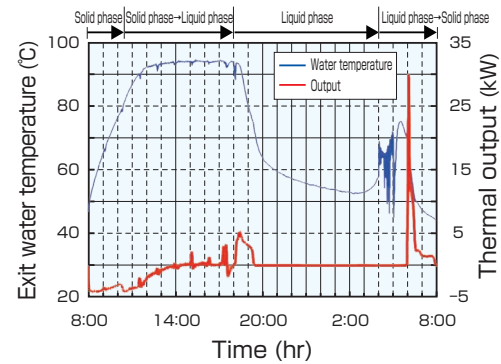

Fig. 4 Example of change in exit water temperature and thermal output of thermal energy storage device (November)

practical, it is necessary to contrive a systematic way to keep the supercooled stage overnight and especially during the weekend, and to optimize the control. It is said that storage technology is one of the keys to energy use in the 21<sup>st</sup> century. We plan to continue to do research and development aiming at practical use of thermal energy storage devices which respond to various targets and temperature ranges.

### Perspectives for the future

In order to make this heat storage device

Energy Technology Research Institute  
**Satoshi Hirano**

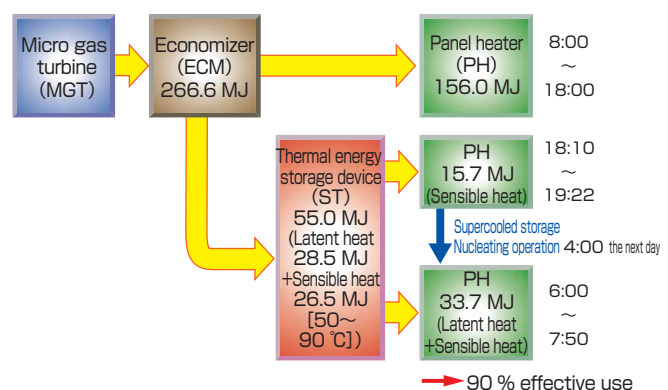

Fig. 5 Example of heat balance of thermal energy storage system (November)

### Reference

[1] S. Hirano and H. Takeuchi: *Performance of supercooled thermal energy storage unit for space heating or Hot Water Supply*, Proc. International Symposium on Innovative Materials for Processes in Energy Systems, A032, 1-5(2007).

# Field Test of a Ground-Source Air-Conditioning and Hot Water Supply System in a Single Family House

## Utilizing the energy beneath our feet

The ground temperatures at 100 m in depth range from 10 to 20 °C in Japan. Among natural sources of heat, the ground is one of the best heat sources in winter, and one of the best heat sinks in summer. The ground heat can be used for various purposes such as air conditioning, warming swimming pools and snow-melting. Moreover, it can be used almost anywhere. The utilization of the ground heat can contribute significantly to reducing carbon dioxide emissions. Also, its utilization for space cooling helps to mitigate the heat-island phenomenon.

Increases in the number of ground-source heat pumps (GSHPs) have been remarkable in the United States, Sweden, Germany, Switzerland and so on. Currently, over one million GSHPs are in use around the world. In contrast, the total number of the GSHPs operating in Japan is estimated to be only 400 at most. The major reasons for this have been high drilling costs, and relatively high electric power costs as compared with those of kerosene and heavy oil. For these reasons, it has been difficult to realize economical advantages with GSHP systems in Japan.

We have been developing systems aiming at the reduction of construction costs and the improvement of energy efficiency. A system which we have developed was put into operation at a single family house in Tsukuba, Ibaraki Prefecture in December 2006 in order to clarify the system's performance and to demonstrate its reliability.

## The air-conditioning and hot water supply system

In our system (Fig. 1), a high-performance ground heat exchanger, the DCHE developed by the author, is utilized to shorten the length of the heat exchanger and hence reduce drilling costs. A direct expansion/condensing unit is also utilized. This makes it possible to reduce the number of component parts and to facilitate the installation of equipment as compared with a conventional system (Fig. 2). This leads to the reduction of construction costs. In addition, a higher heat pump's coefficient of performance (COP) can be expected because of the fewer heat exchange stages and hence the smaller temperature loss in the indoor-side heat transfers circuit. In addition, the reduction in the number of circulation pumps

leads to a higher system's COP.

The total floor space of the single family house is 152 m<sup>2</sup> and a family of four lives in it. The system is used for the air-conditioning of 5 rooms and for providing hot water for a bathtub, a shower and all the sinks in the house.

In this system, one 70 m long DCHE is utilized. The length of this ground heat exchanger is much shorter than conventional ground-coupled systems in Japan. At the bottom of the DCHE, 71 m in depth, the initial temperature of the ground was 16.1 °C. Fig. 3 shows the installed equipment at the single family house.

## Source temperatures and running costs

Fig. 4 shows the changes in the outdoor air temperature and the source temperature of the system while operating the heat pump for air-conditioning. It is clear that higher source temperatures than those of the outdoor air can be used for space heating, and significantly lower source temperatures for space cooling. The average source temperature was higher than the outdoor air temperature by 3.6 °C in January and lower by 9.9 °C in August when the monthly cooling demand was greatest in the year.

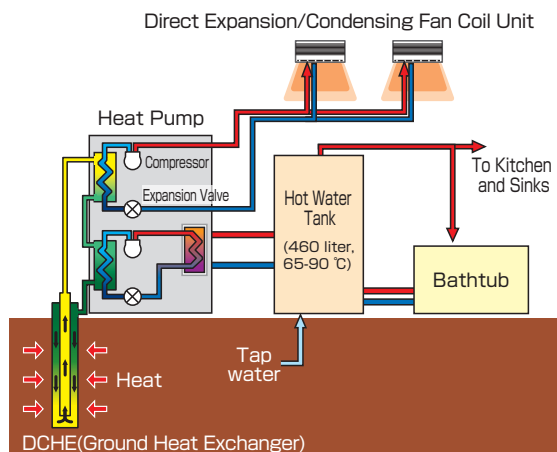

Fig. 1 Concept of the developed air-conditioning and hot water supply system.

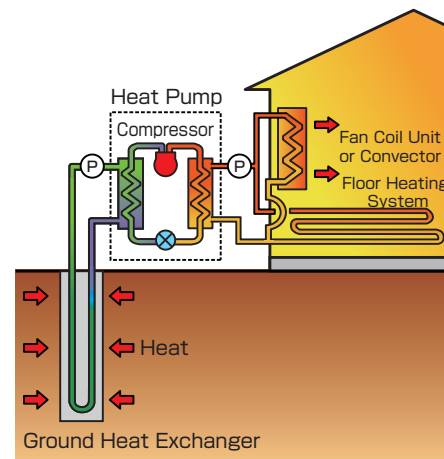

Fig. 2 Concept of a conventional ground-coupled heat pump system.



**Fig. 3 The installed air-conditioning and hot water supply system.**  
From left to right: measurement equipment, heat pump and hot water tank.

This shows that more efficient air-conditioning can be realized with the ground-coupled system than with an air-source system, and in the case of space cooling, significantly greater contribution in energy conservation can be expected.

With the hot water supply (Fig. 5), the source temperature was higher than the outdoor air temperature in colder months in which the hot water demand was relatively great, but lower in warmer months from May to September. However, hot water demand in this period was much smaller than in the colder period. Hence, a comparable value to that of air-source systems can be expected with this system in annual average energy efficiency.

The running costs of conventional systems, which consists of air-source heat pumps for air-conditioning and a hot-water boiler burning natural gas, was estimated to be 142,000 yen per year including consumption tax for houses with similar floor space in the Kanto region. In

contrast, the running costs for one year from the onset of our system's operation was 49,000 yen including consumption tax. Thus, it has been demonstrated that significantly cheaper running cost can be realized with this system.

Meanwhile, the annual average COP of the heat pump was 4.8 for air-conditioning including space heating and space cooling, and 3.2 for hot water supply.

**Reduction of Carbon Dioxide Emissions**

Based on the measured outdoor air temperatures and source temperatures at the house, carbon dioxide emissions were calculated for three different systems. As shown in Fig. 6, it was indicated that carbon dioxide can be reduced by 40 % with our system compared to systems consisting of air-source air conditioning heat pumps and a boiler burning natural gas.

Compared to a system which covers the air-conditioning and hot water supply with only air-source heat pumps, the reduction with our system was estimated to be 16 % considering the power consumption by the main equipment. However, as a complete system including a circulation pump, the reduction ratio decreased to about 4 %.

**Perspectives for the future**

Generally, the utilization of ground heat is competitive in colder regions where the efficiency of air-source heat pumps becomes low. However, the data acquired at the single

family house in Tsukuba has revealed that the utilization of ground heat also has an advantage even in warm areas such as the Kanto region, and the advantage is remarkable in the space cooling season.

Also, it has been demonstrated that the running costs can be significantly reduced with this system compared with conventional systems consisting of air-source air-conditioning heat pumps and a boiler burning natural gas.

On the other hand, it has been indicated that there is a possibility of further reducing carbon dioxide emissions. The reduction of the power consumption of the circulation pump, by searching for more efficient circulation pumps and by employing a flow rate control system with an inverter, could lead to further reductions. The utilization of the outdoor air's heat for the hot water supply in the period when outdoor air temperature is higher than the source temperature is another possible way. In this case, the outdoor air is cooled in summer and the effect in mitigating the heat-island phenomenon becomes greater.

Through the operation of our system at the single family house, the reliability of the system is being verified. The above mentioned improvements and the commercialization of the system are the next tasks.

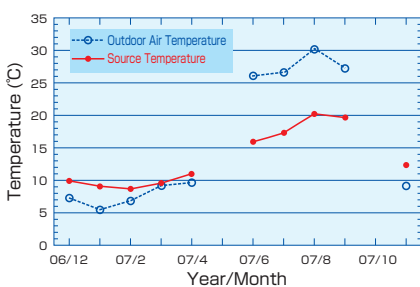

**Fig. 4 Changes in outdoor air temperature and source temperature while operating the heat pump for air-conditioning.**

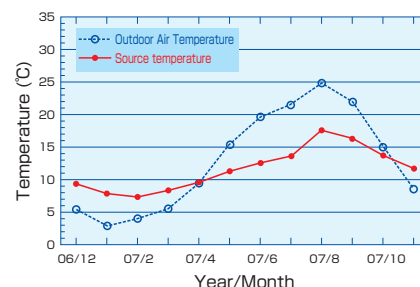

**Fig. 5 Changes in outdoor air temperature and source temperature while operating the heat pump for hot water production.**

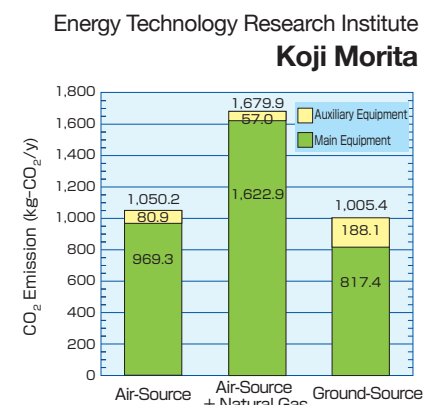

**Fig. 6 Comparison of carbon dioxide emissions**

# Field Test of New Energy and Expansion to Asia

## Introduction

With the rise of crude oil prices showing no sign of stopping, a time when 1 liter of gasoline will cost 200 yen is no longer a joke. Under such circumstances, the popularization of new energy can act not only as an air pollution countermeasure with its clean exhaust, and a global warming measure with carbon neutral bio fuel, but also as an energy security measure.

At AIST, we established the Research Center for New Fuels and Vehicle Technology (NFV) in April, 2007, and are pushing forward the field test studies of various new energies as well as their standardization at home and abroad based on the verified data. Here is presented some of the case examples.

## Field test study and standardization of DME vehicles

With urban environmental load reduction and reduction of oil dependence in mind, various research and developments have been done with dimethyl ether (DME) which does not produce soot when burned and which can be used in diesel engines for heavy-duty vehicles. The Combustion and Engine Research Team (CERT)

of the NFV of AIST, when it was part of the Energy Technology Research Institute of AIST, developed a medium-duty DME truck (Photo 1) with such companies as CO-OP Eco Vehicle Development Co. Ltd., and JFE Holdings, Inc., under the project (FY2002~2004) of Japan Oil, Gas and Metals National Corporation (JOGMEC, former Japan National Oil Corporation). Highway driving tests have been done between such places as Tsukuba and Niigata, the total distance covered has reached 20,000 km, and it has been confirmed that there is no serious trouble concerning durability. Presently, we are doing driving tests collaboratively with a new light-duty DME truck developed by ISUZU Advanced Engineering Center, LTD. (IAEC). It is estimated that this truck will cover a total distance of 100,000 km during 2008, and the data obtained will be reported from Isuzu to the Ministry of Land, Infrastructure, Transport and Tourism and will be reflected in establishing technological guidelines of DME vehicles.

Working towards standardization of automotive DME fuel, concerning components that might be mixed in the fuel during market introduction of automotive DME fuel such

as during DME manufacturing process and distribution process, we are experimentally evaluating engine performance and emission characteristics including trace components by engine testing. From these data, we aim to define the purity of DME and the mixture limit of impurities, and to draw up Japanese technical specifications (TS), and also to register with JIS (Japan Industrial Standards) and ISO (International Organization for Standardization) (FY2008 standard certification research development project of Ministry of Economy, Trade and Industry). At ISO, discussions concerning DME sampling and measuring methods, and ways toward standardization of DME fuel and automotive DME fuel has started since 2007, and NFV has produced an international chairman (ISO/TC28/SC5\*) as well as committee members (ISO/TC28/SC4\*\*, SC5).

\*TC: Technical Committee, SC: Sub Committee, SC5: A sub committee that discusses standardization concerning measurement of liquefied natural gas (LNG) and nonpetroleum liquefied gas fuel

\*\*SC4: A sub committee that discusses standardization



Photo 1 Medium-duty DME truck



Photo 2 Bio-bred DME generation system

**Table Benchmark standard of hundred percent of biodiesel fuel(B100) aimed for blending in diesel fuel**

Items	Units	U.S.	EU	Japan	EAS-ERIA BDF Standard (EEBS):2008
		ASTM D6751-07b	EN14214:2003	JIS K2390:2008	
Ester content	mass%	—	96.5 min.	96.5 min.	96.5 min.
Density	kg/m <sup>3</sup>	—	860-900	860-900	860-900
Viscosity	mm <sup>2</sup> /s	1.9-6.0	3.50-5.00	3.50-5.00	2.00-5.00
Flashpoint	deg. C	93 min.	120 min.	120 min.	100 min.
Sulfur content	mass%	0.0015 max.	0.0010 max.	0.0010 max.	0.0010 max.
Distillation, T90	deg. C	360 max.	—	—	—
Carbon residue (100 %) or Carbon residue (10 %)	mass%	0.05 max.	—	—	0.05 max.
Cetane number		47 min.	51.0 min.	51.0 min.	51.0 min.
Sulfated ash	mass%	0.02 max.	0.02 max.	0.02 max.	0.02 max.
Water content	mg/kg	0.05[vol%]max.	500 max.	500 max.	500 max.
Total contamination	mg/kg	—	24 max.	24 max.	24 max.
Copper corrosion		No.3	Class-1	Class-1	Class-1
Acid value	mgKOH/g	0.50 max.	0.50 max.	0.50 max.	0.50 max.
Oxidation stability	hrs.	3 min.	6.0 min.	(**)	10.0 min. (****)
Iodine value		—	120 max.	120 max.	Reported (**)
Methyl Linolenate	mass%	—	12.0 max.	12.0 max.	12.0 max.
Polyunsaturated FAME (more than 4 double bonds)	mass%	—	1 max.	N.D.	N.D. (***)
Methanol content	mass%	0.2 mal.(*)	0.20 max.	0.02 max.	0.20 max.
Monoglyceride content	mass%	—	0.80 max.	0.80 max.	0.80 max.
Diglyceride content	mass%	—	0.20 max.	0.20 max.	0.20 max.
Triglyceride content	mass%	—	0.20 max.	0.20 max.	0.20 max.
Free glycerol content	mass%	0.020 max.	0.02 max.	0.02 max.	0.02 max.
Total glycerol content	mass%	0.240 max.	0.25 max.	0.25 max.	0.25 max.
Na+K	mg/kg	5 max.	5.0 max.	5.0 max.	5.0 max.
Ca+Mg	mg/kg	5 max.	5.0 max.	5.0 max.	5.0 max.
Phosphorous content	mg/kg	10 max.	10.0 max.	10.0 max.	10.0 max.

(\*) 130deg.C of flashpoint is available instead of measuring methanol content

(\*\*\*) Need data check and further discussion

(\*\*) Meet diesel oil specification

(\*\*\*\*) Need more data & discussion from 6 to 10 hrs.

concerning quality and classification of fuels such as petroleum, LNG, and nonpetroleum liquefied gas fuel

### Research and development of a bio-mixed DME generation system

We have developed a 50 kW-class power generation system with mixed fuel of DME which is clean and diversified as resource, and biofuel which is considered as one of global warming countermeasures, as part of the regional regeneration consortium project of Kanto Bureau of Economy, Trade and Industry (Photo 2). By mixing 10 % mass ratio of biodiesel fuel to DME, it has been confirmed that cold temperature fluidization (cloud point – 16.7 °C) can be secured which will enable usage in almost all regions and seasons in Japan without producing smoke. It has also been confirmed that, by setting up a system where the lubricating oil of fuel injection pump is externally supplied, it is possible to continuously operate an engine even with mixed fuel of liquefied gas and liquid.

This generation system satisfies the product specification of Hokuetsu Industries Co., Ltd. which is in charge of the development project, and its nitrogen oxide emission concentration has been confirmed to be kept lower than 100 ppm. The durability test of 400 hours usage of the developed machine has already been done and there was no detected worsening of performance after the test, no abnormal friction or deterioration of the parts concerning durability was found, and the effectiveness of 10 % palm oil methyl ester-mixed DME was confirmed.

Furthermore, problems raised during the durability test were each solved improving the perfection level, bringing the developed machine closer to practical utility.

### Standardization of biodiesel fuel in East Asia region

At the 2<sup>nd</sup> East Asia Summit (EAS) held in January, 2007, the Cebu Declaration on East Asian Energy Security was signed. At

the Energy Cooperation Task Force (ECTF) working-level meeting of persons in charge of energy policies of the EAS participating countries, it was decided that issues toward unified specification/standardization of biodiesel would be examined. In view of this, a study group of these issues was established within the specialist meeting of the Economic Research Institute for ASEAN and East Asia (ERIA) held in May, 2007.

As part of this ERIA “Standardization of Biodiesel Fuel in East Asia” study group, a working group was established with specialist of East Asian countries as members for the commercialization of good quality biodiesel fuel in the East Asian region, and a benchmark was set on the quality of light oil-mixed biodiesel fuel with harmonized specification as a goal (Table).

Research Center for  
New Fuels and Vehicle Technology  
**Shinichi Goto, Mitsuharu Oguma**

# Field Test Study/Evaluation of Photovoltaic Generation System

## Photovoltaic generation, trump card of global warming countermeasures

G8 Summit was held in July, 2008 at Toyako, Hokkaido, and much attention was paid on global warming countermeasures. At a press conference held a month before on June 9th by then Prime Minister Fukuda, global warming countermeasures (Fukuda Vision) was announced which included aiming for world number one introduction amount of photovoltaic generation<sup>[1]</sup>. It stated that the introduction amount of photovoltaic generation would be increased to ten times by 2020 and forty times by 2030. In order to reach this target, not only are megawatts (MW) level of solar power generation (mega solar generation) needed to be set up all over Japan, but also over 70 % of newly-built residential homes need to select photovoltaic generation.

The introduction amount of photovoltaic generation of Japan has been over 200,000 kW per year during the 5 years since 2003, however, it has been declining since 2005 when it peaked at 300,000 kW<sup>[2]</sup>, and it has fallen behind Germany. On the other hand, Japan is the world's largest producer of solar cells, and of the 910,000 kW

total shipment of 2007, 700,000 kW (77 %) was exported overseas<sup>[2]</sup>. With mega solar generation, large size systems of over 10 megawatts have been completed one after another especially in Spain, Germany and USA, and there are over 40 examples of mega solar generation of over 5 megawatts in the world<sup>[3]</sup>; however, in Japan, only one example at Kameyama Plant of Sharp Corporation and one plan in Wakkanai based on, a field test study of New Energy and Industrial Technology Development Organization (NEDO) exist. Japan is not necessarily suited for mega solar generation because of site limitations, and it is thought that its main stage for widespread use is for residential homes. However, such large-scale plan as mega solar generation will continue to be main stream abroad as plant cost can be reduced by bulk order and total optimization can be done. Japan being a major producer of solar cells, implementing field tests and evaluations of large-scale systems are thought to be meaningful in continuing to export high-quality solar cells to the world.

## AIST mega solar generation

The photovoltaic generation facility of

AIST Tsukuba completed in April, 2004 is one of the nation's largest megawatt-level photovoltaic generation facilities (1 MW). This system consisting of over 200 scattered power conditioners is unprecedented at home and abroad. The sturdiness of the total system with its multiple unit distributed control is effective in terms of generating performance and reliability (availability).

The system has generated a total of over 4 million kWh in the past 4 years, and it has saved electrical energy of the equivalent of approximately 1 % of the electrical power need of AIST Tsukuba Central 1, 2, 3, 7 which are systematically linked. It is estimated that, by this system, 1,200 t of carbon dioxide emission was reduced. These results show that it has achieved its generation objective at construction<sup>[4]</sup> of 1 million kWh per year. The introduction of photovoltaic generation is effective as countermeasure for cutting back on electricity peak demands, and it had a peak cut effect of about 3 % of the peak demand period during the summer.

## Pursuing reliability

With the field test study of AIST mega

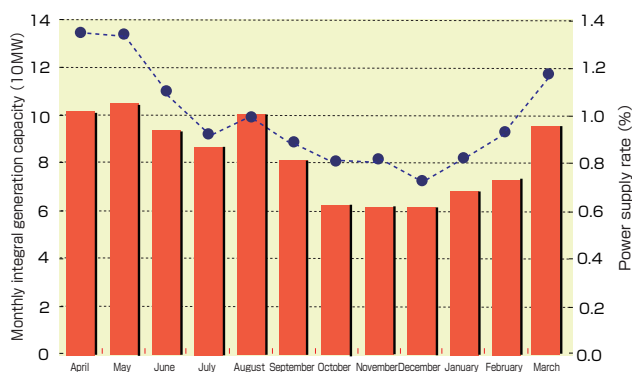

### Past record of generation capacity and power supply rate of photovoltaic generation at AIST Tsukuba (average of 4 years)

Monthly average of generation capacity and power supply rate over the past 4 years is presented in a graph. From March to June and August, the capacity was about 100,000 kWh, from October to December, it was about 60,000 kWh, and 1 million kWh was recorded for a year. This is the equivalent of about 1 % of power demand at Tsukuba Central 1, 2, 3, and 7.

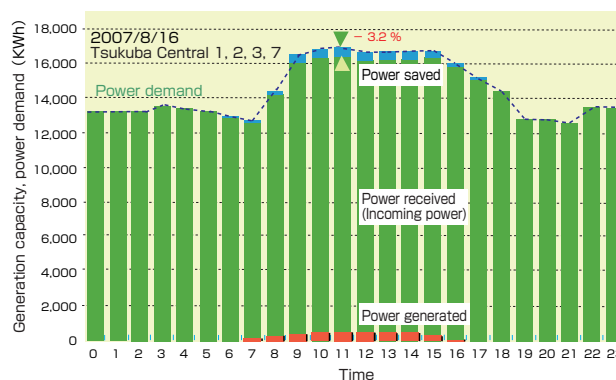

### Peak cut effect of power demand by photovoltaic generation at AIST Tsukuba

This shows the time transition of power demand and photovoltaic generation capacity of the day with the most power demand during the past 4 years. On this day, photovoltaic generation provided 1.1% of power demand. For the power demand peak of 17.0 MW recorded at 11 a.m., the incoming power from the power company was 16.4 MW at the peak time of 11 a.m.; thus achieving 3.2 % of power peak cut.

## The top ten of high generation capacity and power demand at AIST Tsukuba

Power demand is the highest during summer (during school vacation), but photovoltaic generation power capacity is highest in early summer. The reason for this is that the clear, sunny weather of early summer (satsukibare - warm May weather in Japan) is more suitable for solar cell performance than the hot summer weather.

Photovoltaic generation capacity (Tsukuba Central)										
Top 10	First	Second	Third	Fourth	Fifth	Sixth	Seventh	Seventh	Ninth	Tenth
Recorded day	May 3 '06	June 19 '04	May 20 '07	April 6 '06	April 3 '06	May 21 '07	June 18 '04	May 25 '06	May 31 '06	June 4 '07
(kWh)	6,050	5,950	5,900	5,890	5,880	5,850	5,800	5,800	5,780	5,730

Power demand (Tsukuba Central 1, 2, 3, 7)										
Top 10	First	Second	Third	Third	Fifth	Sixth	Seventh	Seventh	Seventh	Tenth
Recorded day	Sept. 28 '05	Aug. 16 '07	Aug. 15 '07	Aug. 22 '07	Aug. 6 '04	July 21 '04	July 27 '04	Aug. 5 '04	Aug. 8 '07	July 7 '04
(10 MW)	39.8	34.9	34.3	34.3	34.2	34.0	33.9	33.9	33.9	33.8

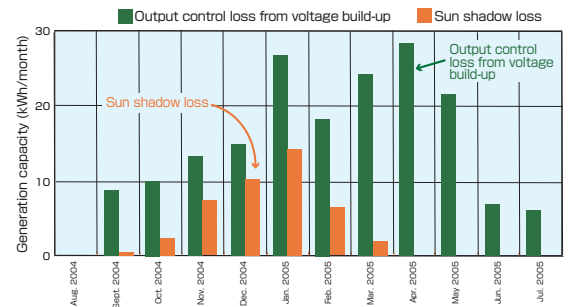

## Example of loss of photovoltaic generation system

With this system (rated output 4 kW), sun shadow loss only occurred during the winter, however, control loss from voltage build-up occurred throughout the year. The quantity of this control loss was proportionally related to the difference in voltage between day and night. The sun shadow loss is an estimate value based on fish-eye photos.

solar generation system, it was not without difficulty that its generated power reached 1 million kWh per year. As the fuel for photovoltaic generation is solar energy that constantly falls to earth, avoiding opportunity loss by system shut down leads to performance realization. Therefore, monitoring the operation status is an important task.

Operation status can easily be monitored by the employees of Tsukuba Central by looking at the digital display indicator. As the digital indicator is placed where there is much traffic at lunch time, we think that many employees have helped in monitoring. As there is a measuring system in supervisory rooms of each area where photovoltaic generation system is linked, the people of the supervisory rooms have also been aware of the operating conditions.

On the one hand, there were intermittent troubles that occurred. However, these were dealt with step by step by repairing and monitoring that there was no great loss in the generation performance as a whole. During these 4 years, 112 solar cell panels, 2 % of the total number, were replaced, and 18 of 211 units of power conditioner (inverter) were repaired or replaced<sup>[5]</sup>. These troubles tended to be focused on certain devices (types), and improvement of initial design and delivery inspection system is expected. To grasp whether adequate electric power is supplied by photovoltaic generation is

as difficult a task as forecasting the weather; and from actual examples of residential photovoltaic generation system, it was discovered through a survey<sup>[6]</sup> that about 40 % of those who installed made wrong estimations and either underestimated or overestimated the electric generating capacity. The trouble mentioned above were detected by comparing viewpoints of specialists with the electric generating capacity simulation. The electric generating capacity simulation predicted 1 million kWh per year, and this information is open to the public on our homepage (www.pvsystem.net). Those who are thinking of installing solar generation systems, please use this information for your diagnosis of installation.

One of the issues in promoting widespread use of photovoltaic generation is solar cell technology of new materials such as thin-film silicon and chemical compounds, in order to evade limitations of silicon resources. Unlike crystal silicon that was used in almost all of AIST

system, thin-film silicon, with high performance during the summer, can cut electricity more effectively during the peak summer period.

As an issue concerning centralized linkage, it was discovered that there is considerable variation of generating capacity of photovoltaic generation system in certain places. 7 units have been installed with identical application and identical positions, however, depending on the voltage difference at the side of the inverter, a system that would suppress and control output and suspend power generation<sup>[7]</sup> is activated. The fact that the voltage is raised at this linkage point is collective responsibility of the whole, and that to restrict the loss to certain parts of the system may be unfair. With future residential areas using photovoltaic generation, it is suggested that there is a need to optimize the collective power generation capacity by collaborative control of a multiple unit system.

Research Center for Photovoltaics  
**Kenji Otani**

## References

- [1] Office of Prime Minister: "Teitanso shakai/Japan" o mezashite (Aiming for "Low Carbon Society/Japan"), (2008) (in Japanese).
- [2] Japan Photovoltaic Energy Association: *Nihon ni okeru taiyo denchi shukka ryo no suiri* (Transition of solar cell shipping volume in Japan), <http://www.jppea.gr.jp/pdf/qlg2007.pdf>(2008) [ PDF52KB ](in Japanese).
- [3] <http://www.pvresources.com>
- [4] Press announcement, April 27, 2004: *Sansoken tsukuba senta ni kokunai saidai no taiyoko hatsuden setsubi ga kansai* (Completion of the largest photovoltaic generation facility in Japan at AIST Tsukuba)(in Japanese).
- [5] Kazuhiko Kato: PVResQ - PV - Reliable, Safe & Sustainable Quality!, Annual Report FY2007(2008).
- [6] AIST, Japan Electrical Safety & Environment Technology, Laboratories: *Taiyoko hatsuden shisutemu kyotytsu kiban gijutsu kaihatsu taiyoko hatsuden shisutemu hyoka gijutsu no kenkyu kaihatsu, heisei 16 nendo-heisei 17nendo NEDO itaku gyomu seika hokoku sho* (Photovoltaic Generation System Common Infrastructure Technology Development Research Development of Photovoltaic Generation System Evaluation Technology, 2005-2006 NEDO Commissioned Project Achievement Report), (2006)(in Japanese).
- [7] Kenji Otani: *Nihon enerugi gakkai shi* (Journal of the Japan Institute of Energy)...(in Japanese).

---

# NEW ENERGY TECHNOLOGY FOR SOCIETY

– Approach by Field Test and Evaluation–

- Field Test Study in Energy 2  
Research Coordinator **Yoshiro Owadano**
  
- Field Test Study of Cogeneration Using Supercooled Thermal Energy Storage 4  
Energy Technology Research Institute **Satoshi Hirano**
  
- Field Test of a Ground-Source Air-Conditioning and Hot Water Supply System in a Single Family House 6  
Energy Technology Research Institute **Koji Morita**
  
- Field Test of New Energy and Expansion to Asia 8  
Research Center for New Fuels and Vehicle Technology **Shinichi Goto, Mitsuharu Oguma**
  
- Field Test Study/Evaluation of Phtovoltaic Generation System 10  
Research Center for Photovoltaics **Kenji Otani**

---

 **AIST** NATIONAL INSTITUTE OF  
ADVANCED INDUSTRIAL SCIENCE AND TECHNOLOGY (AIST)

---

Publication Office, Public Relations Department, AIST  
AIST Tsukuba Central 2, 1-1-1 Umezono, Tsukuba, Ibaraki, 305-8568, JAPAN  
Tel:+81-29-862-6217 Fax:+81-29-862-6212 E-mail:prpub@m.aist.go.jp <http://www.aist.go.jp/>

---